

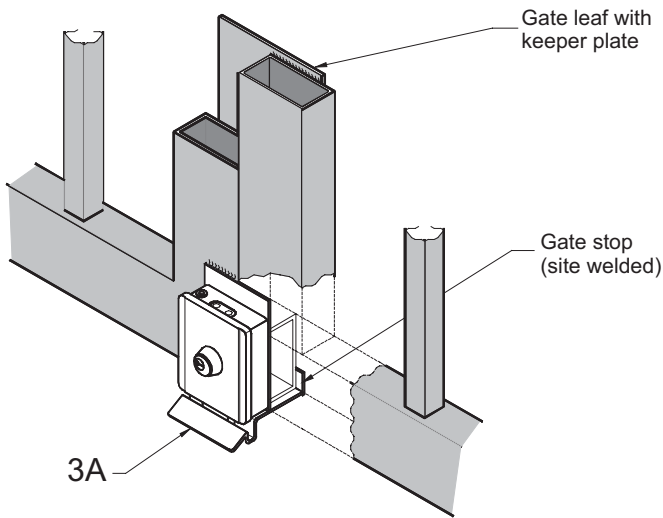

LIFTMASTER

ELECTRIC GATE LOCKS



The swivel dead bolt of the FAAC electric gate lock (400504) and the Viro V90 electric gate lock (400505) are designed for locking automatic and manual gates.

With a zinc plated steel housing and brass lock barrel & latch, the electric locks are manufactured to withstand the harsh outdoor conditions.

Requiring only 12V AC or DC the locks can be easily installed on steel, aluminium or timber gates.

The Viro V90 has a special hold open feature which allows the lock to remain released after the pulse has been applied and will only be relocked again once the gate has been opened and then reclosed.

CENTRAL MOUNTING FOR TWO LEAF GATES WITH KEEPER PLATE

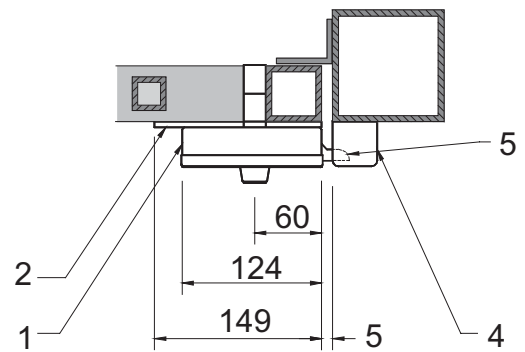
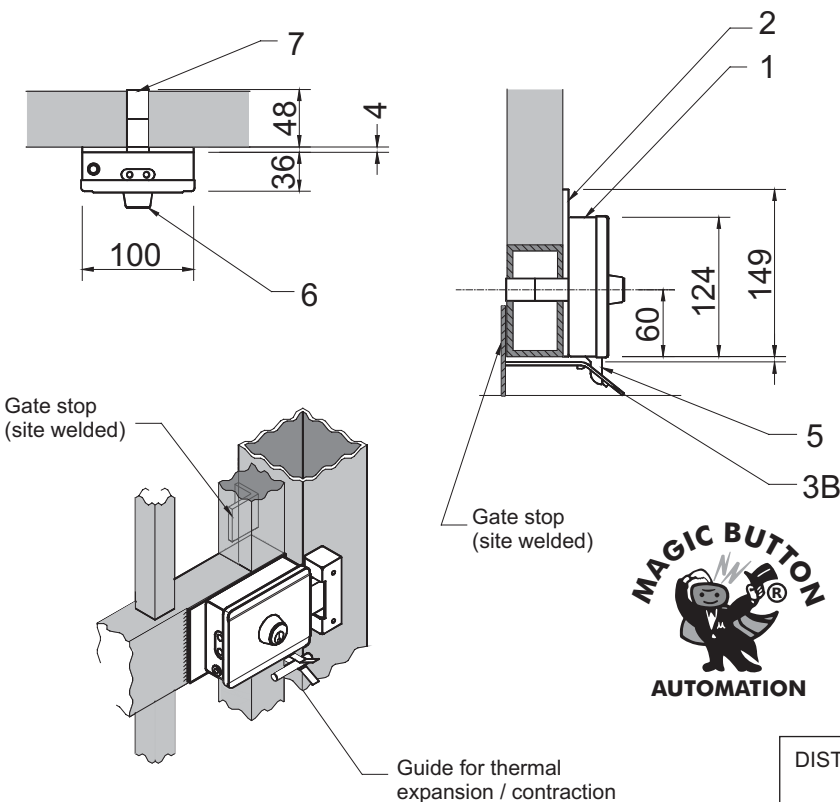

- 1. Lock
- 2. Lock Mounting Plate
- 3A. Latch Plate (V90)
- 3B. Latch Plate (FAAC)
- 4. Latch housing (V90)
- 5. Lock tongue
- 6. Inside tumbler
- 7. Outside tumbler (Std. V90, Option on FAAC)

SIDE MOUNTING FOR SINGLE LEAF GATE

Gate stop not included in lock package

DISTRIBUTED BY:

LIFTMASTER ELECTRONICS PTY LTD A.B.N. 58 000 266 035
PO BOX 54 ALEXANDRIA NSW 1435 AUSTRALIA PH: 61 2 9699 9654 FX: 61 2 9699 8443
www.liftmaster.com.au