



LIFTMASTER®

MAGIC BUTTON® PERFORMANCE

FAST SLIDER



FS10



LPK5

APPLICATION

The Liftmaster Magic Button® Fast Slider is built for intensive and reliable operation with optional increased speed of gate operation. It is suitable for all cantilever and bottom track gates with adequate gate stops which have been appropriately engineered for the application.

CONSTRUCTION

A worm gear reduction gearbox is mounted on a 4mm thick hot dipped galvanised mounting plate which provides 4 x 13mm x 50mm slots for easy installation. An elevated mounting plate provides an installation platform for the logic control and safety accessories. Motor disengagement from the gate, for manual operation, is by way of a simple lever. Speed deceleration control is managed by dedicated limits coupled with appropriate selectable inverter settings. Gates over 11 metres require external limits. The entire unit is covered by a stainless steel enclosure.

MOTOR AND GEARBOX

The inverter driven 0.55Kw motor has an electric brake and is constructed to withstand harsh conditions. To suit the application, a selection of two gearboxes are offered, with other ratios available upon request. Conveniently only 10 amp 240V power is required

SPEED

Depending upon the application, mass and engineering of the gate, a gate speed of up to 800mm per second is achievable. The gate speed can be variable for both opening and closing.

LOGIC CONTROL

The operational sequencing of the motor is achieved by the exclusive Magic Button MB106 or MB206 control board. Depending upon trigger and safety accessories the motor can be selected to be operated in fully automatic mode or by manual operation for open, close and stop. A partial opening of the gate width to suit an individual application outside of the normal full operational gate width is also achievable. In the case of a 240V power interruption an appropriate uninterrupted power supply unit is available. Building management systems, time clocks, fire alarms, access control, lighting, CCTV recording and other interface devices can all be incorporated by the Magic Button logic control.

SAFETY

A sensitive inbuilt adjustable clutch offers an excellent last resort anti crushing device. However, the installation of appropriate safety devices applicable for the situation is mandatory. A power isolation switch for maintenance is provided.

ACCESSORIES

- ▶ Photo electric beams
- ▶ Vehicle Detectors
- ▶ Safety edge profile
- ▶ Emergency stop controls
- ▶ Flashing lights
- ▶ Traffic lights
- ▶ Radio & access control



FS10 & LPK5 TECHNICAL SPECIFICATIONS

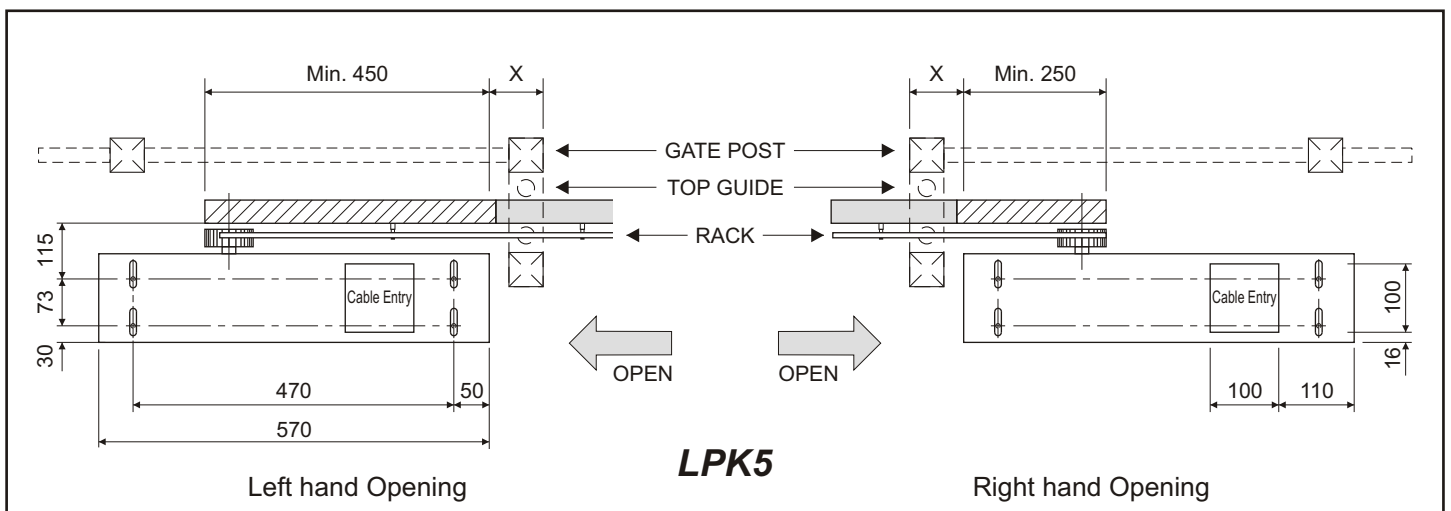
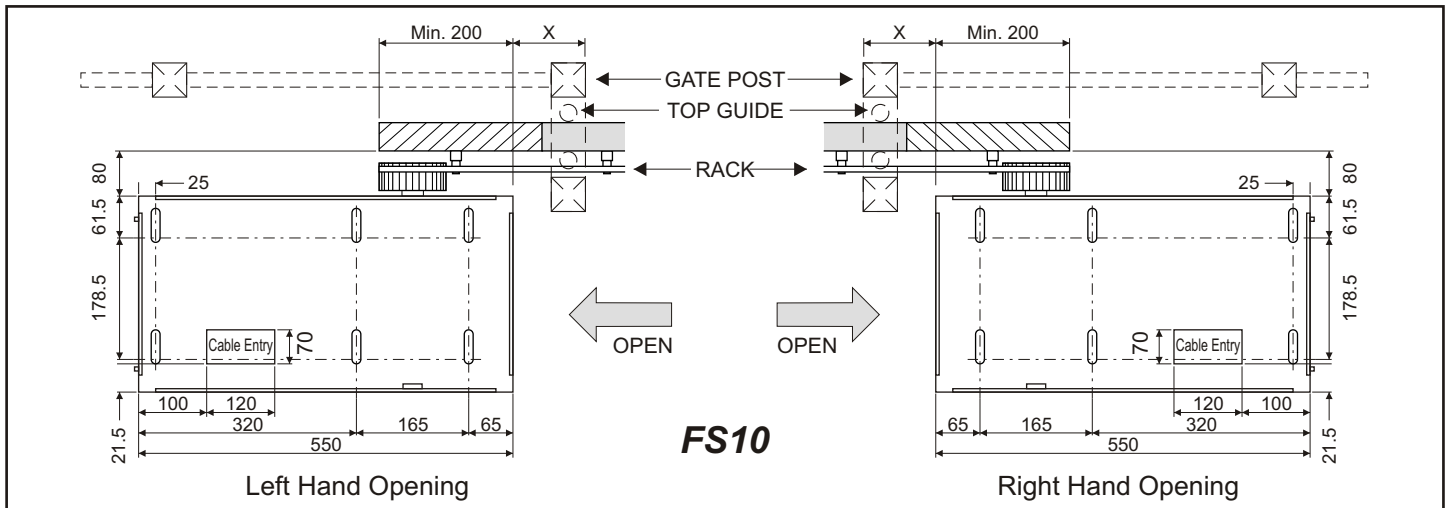

TECHNICAL DATA

Power Supply Required	240V AC
Absorbed Power (Watts)	550 W
Current Drawn (Amps)	4 Amp
Electric Motor	4 Poles - 1370 RPM
Standard Reduction Ratio	36 : 2
Max Speed with 36:2	800mm/sec
Start-up Torque with 36:2	144 kg
Nominal Torque with 36:2	91 kg
Locking Torque with 36:2	80 kg
Optional Reduction Ratio	29 : 1
Max Speed with 29:1	480mm/sec
Start-up Torque with 29:1	196 kg
Nominal Torque with 29:1	124 kg
Locking Torque with 29:1	326 kg
Pinion Size	Z25 (110mm diam.)
Rack	Module 4
Type of Oil	Mobil Gear 627 (or equivalent)
Temperature Range	-15°C to +45°C
Weight of Operator	42 kg

FS10

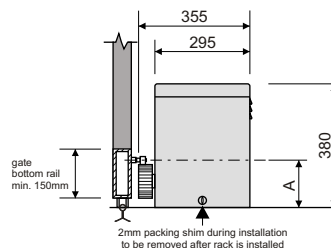

Rack Mounting Heights

A	Nylon Rack - 110mm
	Steel Rack - 150mm

This measurement is from the ground to the centre of the rack mounts.

LPK5

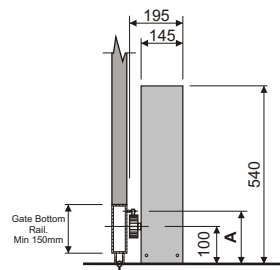

Rack Mounting Heights

A	Nylon Rack - 130mm
	Steel Rack - 165mm

This measurement is from the ground to the centre of the rack mounts.

Liftmaster is not responsible for the failure to observe good technique in the construction of the structure to be motorised, or for any deformation that may occur during use.

Specifications and details of this brochure are to be read in conjunction with the Magic Button Fast Slider operator's manual.