

# MB226

# LOGIC CONTROL

# LOW VOLTAGE

MADE IN AUSTRALIA

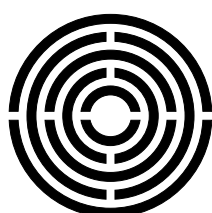
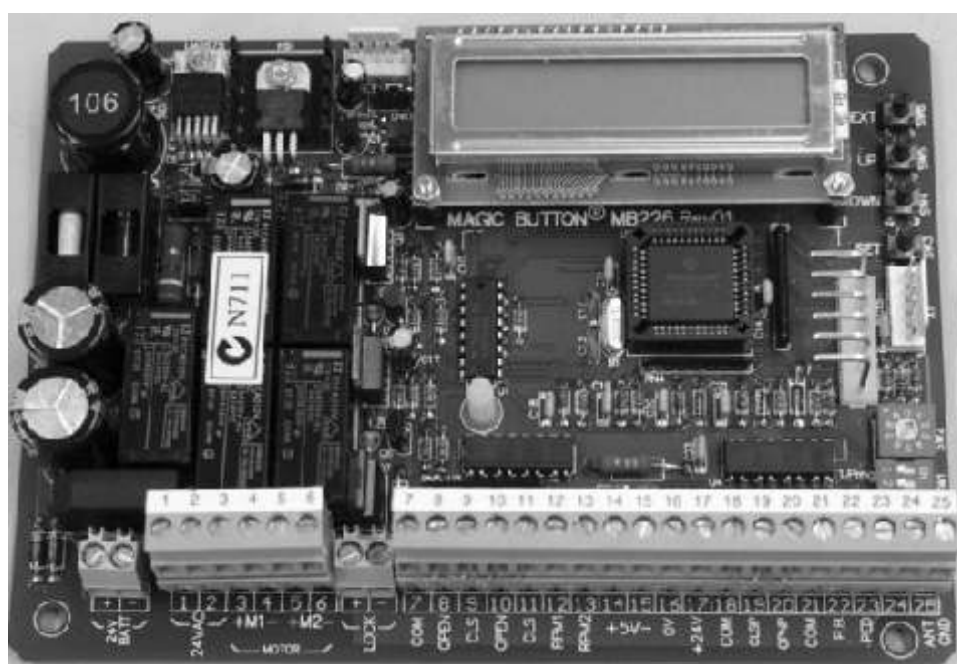

# LIFTMASTER

**Please read these instructions  
carefully before adjusting the  
Liftmaster Magic Button MB226  
control board's default parameter  
settings**

# 1.0 MB226 MAIN FEATURES

- ▶ LCD display with back-light
- ▶ Micro controller design
- ▶ Rotary switch mode selection
- ▶ End of travel slow down with adjustment
- ▶ Motor force control with adjustment
- ▶ Suitable for either 12V or 24V motors
- ▶ Suitable for single or dual motors with or without limits
- ▶ Back pressure release for electric locks
- ▶ Electric lock or magnet output
- ▶ Leaf delay control
- ▶ Inputs for push button and pedestrian
- ▶ Pedestrian access control
- ▶ P.E. 1 (close) inputs & P.E. 2 (open) inputs
- ▶ Output to support relays for lights
- ▶ Output for indication of board status
- ▶ Backup closing timer
- ▶ 6 pin receiver compatible
- ▶ On board antenna input
- ▶ 24V DC power supply protected by 1 amp fuse
- ▶ Optocoupler protection on all inputs
- ▶ LED indicators on all inputs for visual indication on input status
- ▶ Resettable and non-resettable counters
- ▶ Different motor speed selectable
- ▶ Support relay P.E. or pulsing P.E.
- ▶ Current sensor
- ▶ Input for RPM sensor
- ▶ On board 12V or 24V battery charging circuit

**Note:** The availability of some of this control board's features are dependent upon individual applications and motor drive configuration. Qualify feature suitability before use

## **2.0 IMPORTANT SAFETY INSTRUCTIONS**

Please read these important safety rules. Failure to comply with the following safety rules may result in serious personal injury and or property damage.

**2.1** When the MB226 logic control board is used to control gate, door, and barrier gate operating equipment the following factors **MUST** be taken into account:

**A)** Appropriate safety devices relevant to the particular application must be incorporated into the installation of all moving structures

**B)** Safety devices need to be regularly checked for the correct operation

**C)** The gate or door must be able to be freely moved by hand before motorisation

**D)** Warning signs must be visibly installed on either side of the structure

**E)** All programming must be undertaken by qualified technicians

**F)** Any device used to initiate the logic controller must be kept away from children

**G)** Wind loading on the operated structures will unavoidably alter operation functions

**2.2** Do not activate the MB226 logic control board unless the moving structure is in full and clear view and free of objects such as vehicles and people

**2.3** The MB226 logic controller must be connected to properly approved earthed 240V power supply

**2.4** The main power supply must be disconnected before making any repairs

**2.5** Any additional device(s) utilising the MB226 on board DC power supply must not exceed, under load, the total transformer Amp rating

**2.6** Water, dust, and insect presence on the MB226 logic control board must be prevented

**2.7** Do not leave packing materials (plastic, polystyrene, etc.) within reach of children as such materials are potential sources of danger

**2.8** Liftmaster declines all liability caused by improper use or use other than that for which the automated system was intended

**2.9** Do not install the equipment in an explosive atmosphere: the presence of inflammable gas or fumes is a serious danger to safety

**2.10** Liftmaster is not responsible for the failure to observe good technique in the design and construction of the structure(s) to be motorised and or any deformation that may occur during use

**2.11** If parameter P15 (Back Up Timer) is used the door/gate, once the run time is complete or the limits reached, will **automatically close** when the set value of back up time has expired. This closing will occur **without warning, an appropriate safety device must be installed**

**2.12** The effectiveness and compatibility of parameter P26 is dependent of the type of motor to be controlled, qualify the suitability of P26 before use

## 3.0 INSTALLATION GUIDELINES

All electrical works must be carried out by a qualified electrical contractor in accordance with local authority regulations.

Following is a list of installation guidelines:

**3.1** Motor supply voltage (section 4), battery backup voltage (P24), lock method (P24) and PE type (P16 & P17) must be set

**3.2** Input power supply to the transformer is 240V 3 wire (Active, Neutral, and Earth). The input supply must have some means of power isolation.

**3.3** All wiring conduit and cable gland entries to control box should be via the base only.

**3.4** The recommended motor wire size is 1.5mm<sup>2</sup> multistrand. For the control circuits the wire size is 0.5mm<sup>2</sup> stranded. High and low voltage cabling should not be run in the same conduit.

**3.5** All control and limit switch inputs must be DRY switch contacts only. Ensure that all devices being used for gate/door activation have dry contact outputs before connecting to control board. If the device has a voltage output, a relay will be required.

## 4.0 LNK's

**LNK1:** 1+2 = for 24VDC motor (use 24VDC transformer)  
2+3 = for 12VDC motor (use 12VDC transformer)

**LNK2:** 1+2 = for 24V battery backup charging circuit  
2+3 = for 12V battery backup charging circuit

## 5.0 WIRING MOTORS AND ACCESSORIES TO THE CONTROL BOARD

1. Connect motor to control board. If one motor is used connect it to M1 terminals and remove M2 limit wires from terminals 10 and 11. If electric lock is used the lock must be mounted on M1 gate. Once motors are connected to control board, manually move gate/door to the mid position and engage the motor.

2. Turn power on to control board and activate motor(s) (using push button or programmed remote etc). Motor(s) should move towards open position. If the gate/door moves towards closed position, switch power OFF and reverse open/close motor wires (and open/close limit wires where used). Turn power ON and re-test for correct motor operating direction from mid position

3. Once correct motor direction is established, the board parameters can be modified to suit the installation, and the mode selected.

## **6.0 OPERATIONAL NOTES**

1. Normal operation when an obstruction is “sensed” is motor travel reversed on closing and stop on opening. During slow down (open or close) the motor/s will only stop (next direction is mode dependent).

2. Gate motors without limits. If the gate leaf hits the open or closed travel stop when the MB226 is NOT functioning in SLOW DOWN MODE the gate leaf will either; A) stop if opening B) reverse if closing. To rectify this issue ADD slow down time (P10 & P11) and/or REDUCE overall travel time (P2 & P3) to allow slow down time to function.

3. The speed of a DC motor is directly affected by the gate leaf weight or wind loading. If the motor travel time is affected by this in either direction, the extra open and extra close time parameters (P27 & P28) need to be used to allow the gate leaf to reach the open or closed position. The MB226 control board will ignore any extra travel time not used, so extra travel time can be liberally selected.

## **7.0 STATUS INDICATORS L1 - L12**

**L1** - Motor one open limit input status: normally ON, OFF when open limit activated

**L2** - Motor one close limit input status: normally ON, OFF when close limit activated

**L3** - Motor two open limit input status: normally ON, OFF when open limit activated

**L4** - Motor two close limit input status: normally ON, OFF when close limit activated

**L5** - Safety input close indicator: indicates if safety input obstructed, MUST be OFF for board operation

**L6** - Safety input open indicator: indicates if safety input obstructed, MUST be OFF for board operation

**L7** - ON indicator for PB input

**L8** - ON indicator for PED input

**L9** - Board status indicator: indicator OFF when the board is idle and the motor is in the CLOSED position. Once PB or PED input made, then indicator remains ON until the cycle CLOSE-OPEN-CLOSE is complete either by limit(s) or when the close travel time setting is expired

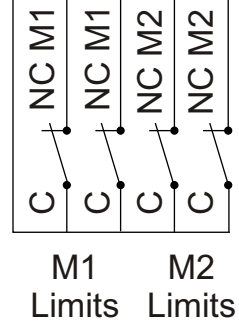
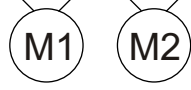
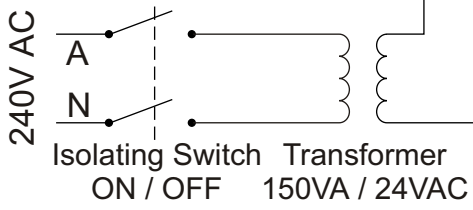
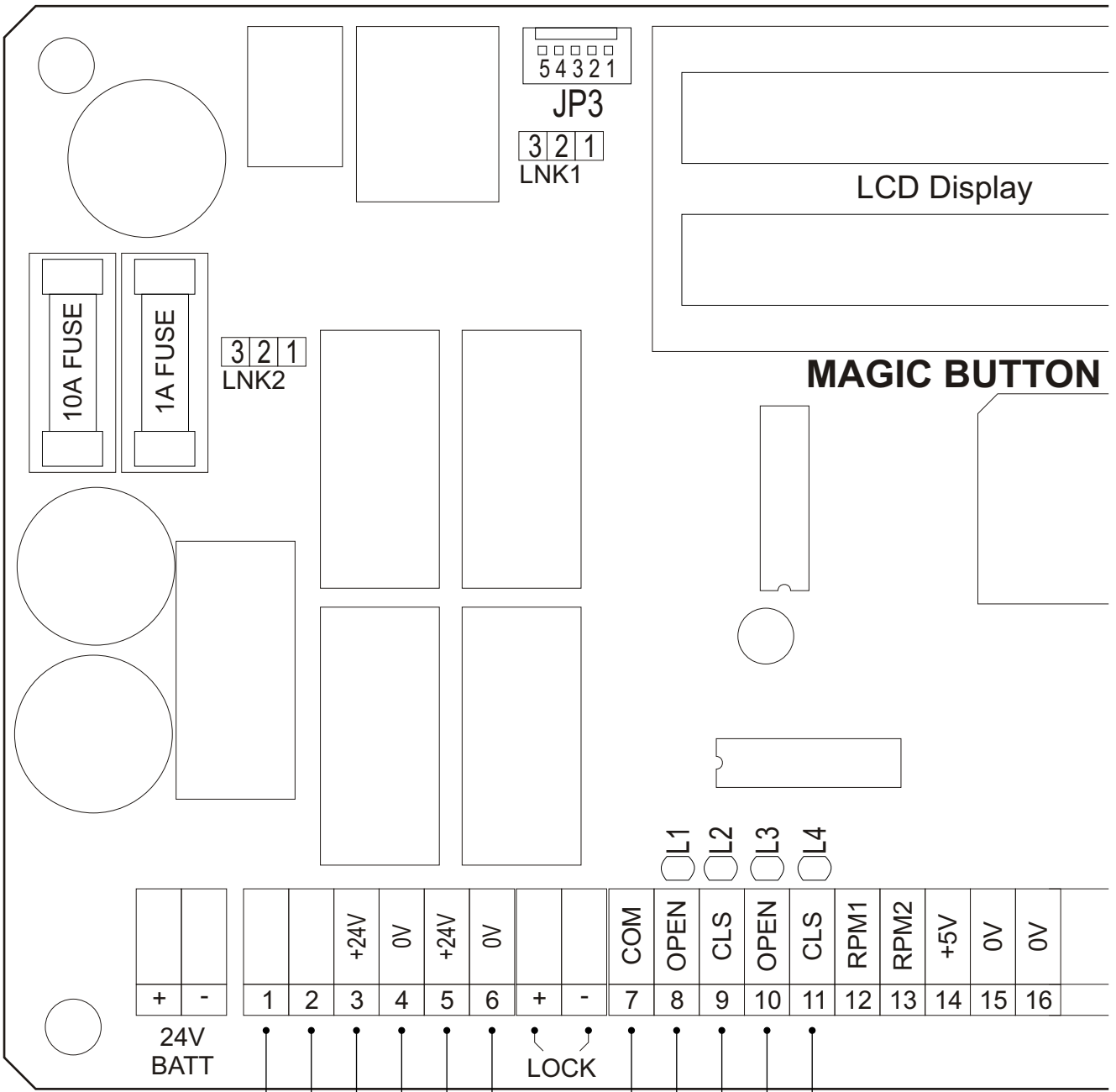



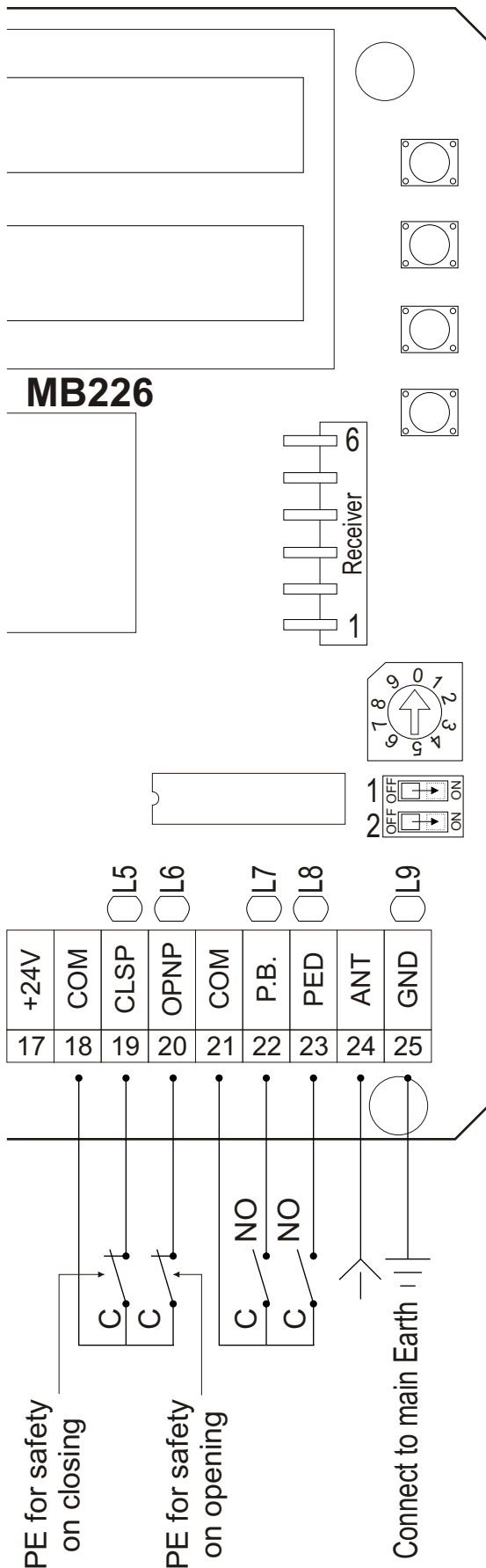

← NEXT: Move to the next parameter

← UP: Increase the parameter value

← DOWN: Decrease the parameter value

← SET: Save the parameter value

Mode Selection: 1. Pulse open / pulse close  
 2. Pulse open / auto. close  
 3. Pulse open / P.E. close  
 4. Counting mode

← Program Switch: Enables programming

← Back-light Switch: Activates LED display back-light

**Note on Fuses:** before changing the fuse(s), identify the cause of the fault, rectify, and then check board functionality including slow down speeds.

**Note:** +24V power supply is 1A

## MB226 CONTROL BOARD FOR 12V/24V DC 5A MOTORS

LIFTMASTER ELECTRONICS PTY LTD  
 Phone: (02) 9699 9654 Fax: (02) 9699 8443

[www.liftmaster.com.au](http://www.liftmaster.com.au)

MB226 - 0807 - REV.01

## 8.0 MB226 MODE SELECTIONS

A '0' to '9' rotary switch is used to select the operating mode. See below for list of modes:

### **MODE 1                                  DOMESTIC                                  POSITION 1**

Gate/door opens on impulse, and closes off a 2nd impulse. While opening a pulse will stop the gate/door from fully opening. The next pulse will close the gate/door.

When Close PE used and the Close PE is interrupted while closing or a pulse is applied, the gate/door will re-open and a second pulse is required for the gate/door to re-close.

### **MODE 2                                  AUTO CLOSE                                  POSITION 2**

Photo Electrics are mandatory for this mode. Gate/door opens on impulse and closes automatically after preset time (P3).

While closing, if the Close PE is interrupted or a pulse is applied, the gate/door will re-open fully and re-close after the preset time (P4) expires and PE's are cleared.

### **MODE 3                                  PHOTO ELECTRIC CLOSE                                  POSITION 3**

Gate/door opens on impulse, and closes only after the PE is broken and cleared. While closing, if the Close PE is interrupted, the gate/door will re-open fully and close after preset time (P4).

### **MODE 4                                  COUNTING MODE                                  POSITION 4**

The number of pulses on the Push Button are counted, and gate/door will only close when the Close PE is activated the same number of times as the pulses on the Push Button. Note: If 2 photo electrics are used this mode is not possible.

## 9.0 HOW TO MODIFY THE PARAMETERS

Note that the board parameters can only be modified while the board is inactive (LED 9 is off) and the door/gate is in the closed position. Factory supplied board is preset to default settings and must be site adjusted.

1. Set switch No.1 (program switch) to ON. To turn the display back-light on, set switch No.2 to ON
2. Display will show the first parameter, P1
3. To change the parameter value press UP or DOWN buttons
4. To save the selected value, press the SET button
5. To modify the next parameter, press NEXT
6. To exit programming, set switch No.1 OFF

The following is a list of parameter values that can be modified. 'P' = parameter, 'M' = motor, 'Def' = default, 'Now' = saved parameter value.

MB226 is a universal 12/24V control board, suitable for any applicable motors to 5 Amp.

The motor type must be selected in P1. Liftmaster has customised the following motor types to optimise performance.

Type 1 - Liftmaster LYN & SCS motors

Type 2 - Liftmaster ART & SUB motors. FAAC, Genius & ATA motors

Type 3 - Universal type motors to 5 Amp : Contact Liftmaster for further details.

DISPLAY ON LCD	COMMENT	RANGE	MY SETTINGS
P1 = Motor Type Def: 0 Now: 0	Select Motor Type, 0 - Board will not operate, 1, 2 or 3 (see above)	0 – 3	
P2 = M1 Travel Time Def: 5 Now: 5.0s	Set motor 1 travel time	0 – 99 secs	
P3 = M2 Travel Time Def: 5 Now: 5.0s	Set motor 2 travel time	0 – 99 secs	
P4 = Auto CIs Delay Def: 1 Now: 1.0s	Set hold open time delay before closing	0 – 99 secs	
P5 = M1 Close Delay Def: 1 Now: 1.0s	Motor 1 closing leaf delay	0 – 10 secs	

P6 = M1 Open Delay Def: 0 Now: 0.0s	Motor 1 opening leaf delay	0 – 4 secs
P7 = M2 Open Delay Def: 2 Now: 2.0s	Motor 2 opening leaf delay	0 – 4 secs
P8 = M1 Force Adj Def: 50% Now: 50%	Set motor 1 force	30 – 100 %
P9 = M2 Force Adj Def: 50% Now: 50%	Set motor 2 force	30 – 100 %
P10 = M1 Slow Down Def: 0 Now: 0.0s	Motor 1 slow down prior to stopping	0 – 10 secs
P11 = M2 Slow Down Def: 0 Now: 0.0s	Motor 2 slow down prior to stopping	0 – 10 secs
P12 = M1 Soft Start Def: 0 Now: 0.0s	Motor 1 soft start	0 – 5 secs
P13 = M2 Soft Start Def: 0 Now: 0.0s	Motor 2 soft start	0 – 5 secs
P14 = Lock Shunt Def: No Now: No	Motor 1 to run forward from closed 1.5 secs before opening	No – Yes
P15 = Back Up Timer Def: 0 Now: 0.0s	Mode 3 only. Close door/gate if back out occurs & close PE/loop not triggered. WARNING: must use safety devices	0 – 65 secs
P16 = Open PE Type Def: RLY Now: RLY	Set PE type being used, RLY - Relay PLS - Pulse	RLY - PLS
P17 = Close PE Type Def: RLY Now: RLY	Set PE type being used, RLY - Relay PLS - Pulse	RLY - PLS
P18 = PE Reverse Def: Yes Now: Yes	Motor reverses when PE/Loop triggered if motor closing. Next motor direction mode dependent. If set to NO motor stops when PE/Loop triggered. Next motor direction mode dependent	No – Yes
P19 = Opn PE ReOpen Def: No Now: No	During opening cycle & Open PE is broken gate leaf will stop. Once Open PE cleared gate leaf will either re-close = NO or re-open = YES	No – Yes
P20 = PED Travel Def: 5 Now: 5.0s	Motor 1 only. Set pedestrian mode travel time	0 – 99 secs
P21 = PED Auto Close Def: No Now: No	Set pedestrian mode to automatic close	No - Yes Refer P4

P22 = Lock Pulse Def: 3 Now: 3.0s	Set lock pulse duration	0 – 4 secs	
P23 = Lock On Cls Def: No Now: No	If set to YES the lock will activate on the start of closing cycle	No – Yes	
P24 = Lock/Magnet Def: Lok Now: Lok	Configure lock relay to control lock (power normally off) or magnet (power normally on)	Lock - Magnet	
P25 = Pwr Fail Close Def: No Now: No	YES - gate/door will close automatically when power failure is restored, NO - gate/door will require a pulse to activate	No – Yes	
P26 = Motor Speed Def: 10 Now: 10	Motor torque is speed related, as speed is reduced motor torque is reduced	1 - 10	
P27 = ExtraOpnTime Def: 2 Now: 2.0s	Add extra open time to P1 and P2 to compensate for wind loading or mechanical loading	0 –10 secs	
P28 = ExtraClsTime Def: 2 Now: 2.0s	Add extra close time to P1 and P2 to compensate for wind loading or mechanical loading	0 –10 secs	
P29 = Battery Type Def: 24 Now: 24	Back up battery type: 2x 12V battery for 24V system 1x 12V battery for 12V system	24V - 12V	
P30 = Battery Low Opn Def: No Now: No	NO - gate/door will remain closed when battery is low, YES- gate/door will open when battery is low	No - Yes	
P31 = RPM Sense Def: No Now: No	When RPM sensor applicable, used as a back up for safety Leave as <b>Def: NO</b> if battery backup used	No – Yes	
P32 = Total Cycles #Cycles = 0000000	Non resettable cycle counter	Cycle = one complete	
P33 = Resettable Cycl #Cycles = 0000000	Resettable cycle counter	close - open - close	
P34 = Reset Cycles Def: No Now: No	Reset parameter P32		
P35 = Reset Default Def: No Now: No	Reset all parameters P1 to P34 to the default values (excluding P32)		
P36 = Software Rev Revision 2.1	Software version		

## 10.0 JP3 OUTPUT OPTION

The use of JP3 requires an optional plug

JP3 output is compatible with all the previous Liftmaster IK series control boards. JP3 can be used to start a timer (for example - on garden lights) or a relay kit could be plugged into it and used to control warning lights.

□ 1	← AUX open signal	— Pin1 output is ON during opening cycle
□ 2	← AUX close signal	— Pin2 output is ON during closing cycle
□ 3	← +12V	— Pin3 is +12V can be used to supply accessory max, 100mA
□ 4	← Common AUX signal	— Pin4 is <b>0V</b> output
□ 5	← Board status output	— Pin5 is the board status output, ON when the board is active

\* Option 1 is the default setting on the MB206

## 11.0 RPM SENSOR

The Liftmaster ART324 motor can have RPM sensing for extra safety. To activate, NO default setting of P30 needs to be changed to YES ART terminals to MB226 terminals

M1 - 6 to 14, 7 to 15, 8 to 12

M2 - 6 to 14, 7 to 15, 8 to 13

## 12.0 PULSING FAIL SAFE PHOTO ELECTRIC

Pulsing fail safe photo electric is a two-wire system, and PE does NOT have a relay output. To use pulsing photo electric change P16 and/or P17 setting to PLS in menu.

Wiring Diagram for Pulsing Fail Safe Photocell

Safety on Closing Set (Reverse)

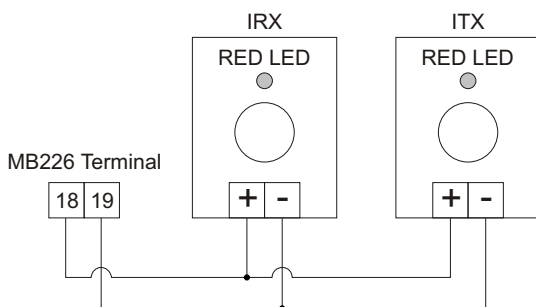

Red LED constant ON = PE aligned  
Red LED flashing = PE unaligned

Safety on Opening Set (Stop)

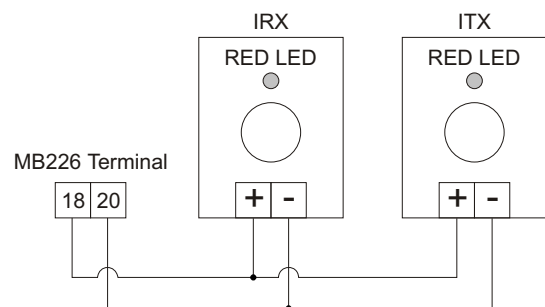

Red LED constant ON = PE aligned  
Red LED flashing = PE unaligned

# NOTES

A series of horizontal dotted lines for writing notes, spanning the width of the page.

# OTHER LIFTMASTER PRODUCTS

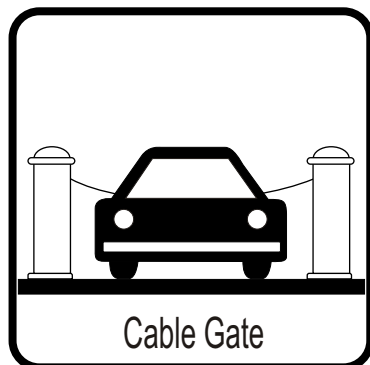
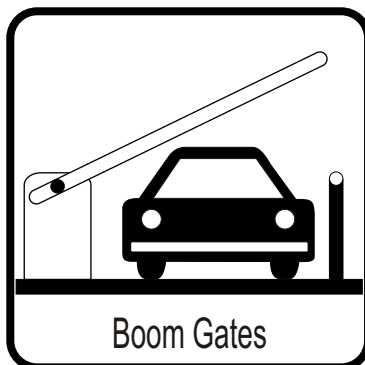
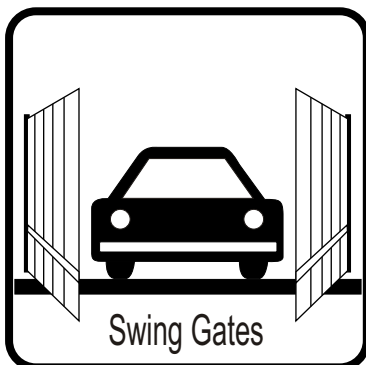
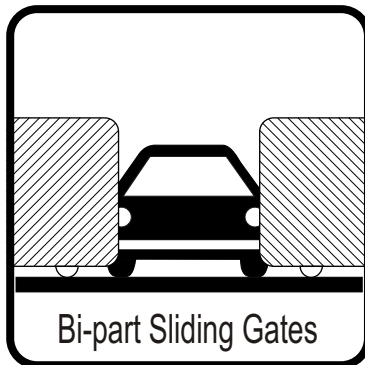
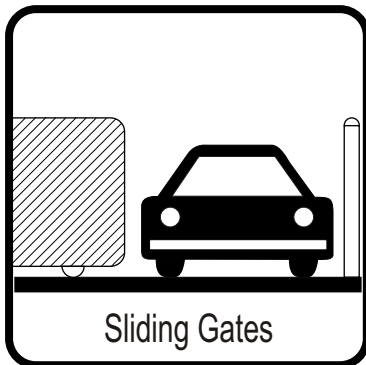
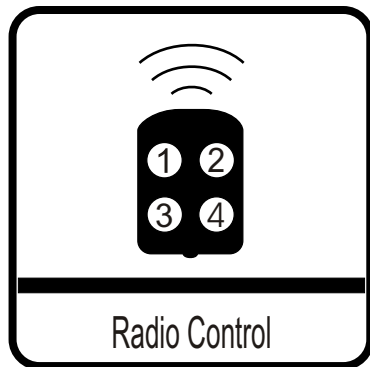
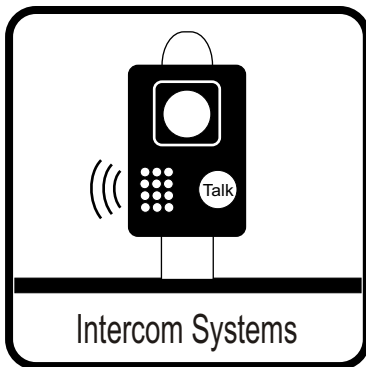
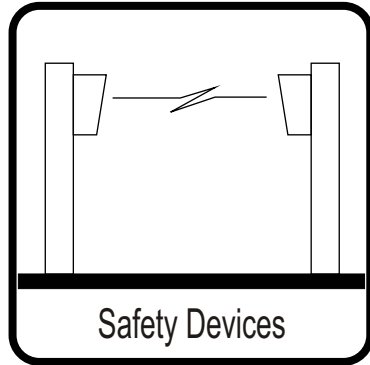
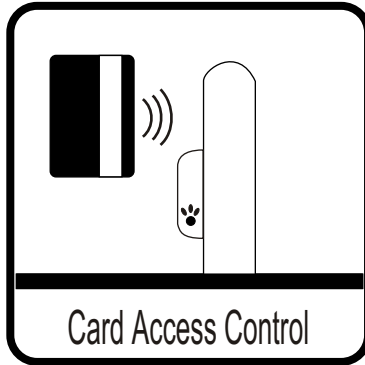
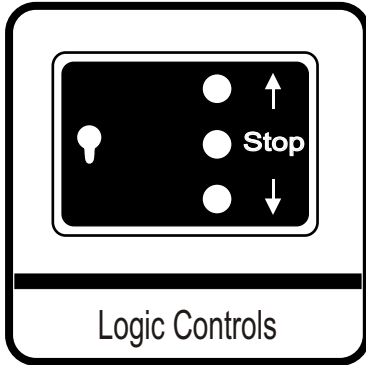

## DOMESTIC • COMMERCIAL • INDUSTRIAL

LIFTMASTER ELECTRONICS PTY LTD A.B.N. 58 000 266 035

PO BOX 54 ALEXANDRIA NSW 1435 AUSTRALIA

PH: 61 2 9699 9654 FX: 61 2 9699 8443

[www.liftmaster.com.au](http://www.liftmaster.com.au) [salesdesk@liftmaster.com.au](mailto:salesdesk@liftmaster.com.au)

As Liftmaster Electronics policy is one of constant improvement, we reserve the right to alter any part of these specifications without notice and without incurring any obligation.