

IMPORTANT NOTICE FOR THE INSTALLER

GENERAL SAFETY INSTRUCTIONS

- 1) **WARNING! For reasons of safety, all the instructions in this manual must be observed scrupulously. Improper installation or misuse of the product may result in serious injury.**
- 2) Read the instructions carefully before installing the product.
- 3) Packaging material (plastic, polystyrene etc.) is a potential hazard and must be kept out of reach of children.
- 4) Keep these instructions for future reference.
- 5) This product has been designed and manufactured only for the use stated in this manual. Any use other than that expressly indicated may result in damage to the product and/or risk of injury.
- 6) FAAC S.p.A. shall not be liable for any damage or injury caused by improper use of the automation or by any use other than that for which it is intended.
- 7) Do not install this device in explosive atmospheres: the presence of flammable gas or fumes is a serious hazard.
- 8) Mechanical structural elements must comply with UNI8612, CEN pr EN 12604 and CEN pr EN 12605 standards. For countries outside the EC, mechanical structural must comply with the above standards in addition to any national safety standards, in order to obtain a reasonable degree of safety.
- 9) FAAC cannot be held responsible for failure to observe technical standards in the construction of the gates on which the automation is installed, or for any deformation of the gates which may occur during use.
- 10) Installation must comply with UNI8612, CEN pr EN 12453 and CEN pr EN 12635. The degree of safety of the automation must be C+D.
- 11) Before carrying out any operations on the system, disconnect the electrical power supply.
- 12) Install a multi-pole switch on the supply line to the automation with a contact opening distance of 3 mm or more. We recommend the use of a 6A thermal magnetic circuit breaker with multi-pole switching.
- 13) Ensure that a residual current device with a trip threshold of 0.03A is installed upstream of the automation system.
- 14) Check that the earthing system is installed correctly and is efficient. Connect the metal parts of the gate and the yellow/green wire of the operator to the earthing system.
- 15) The automation is fitted with an anti-crushing safety system consisting of a torque control device which, in all cases, must be used in conjunction with other safety devices.
- 16) The safety devices (e.g. photocells, safety edges, etc.) protect areas where there is a mechanical movement hazard, e.g. crushing, entrapment and cutting.
- 17) Each installation must be fitted with at least one flashing light (e.g. FAAC LAMP, MINILAMP etc.) and a warning sign suitably fixed to the gate, in addition to the safety devices as per point 16 above.
- 18) FAAC cannot be held responsible for the safe and correct operation of the automation in the event that parts other than FAAC original parts are used.
- 19) Use only FAAC original spare parts for maintenance operations.
- 20) Do not carry out any modifications to automation components.
- 21) The installer must supply all information regarding manual operation of the system in the event of an emergency and provide the end-user with the "End-user Guide" supplied with the product.
- 22) Do not allow any persons, especially children, to stand in the vicinity of the automation when in operation.
- 23) Keep the remote radio controls and any other control devices out of the reach of children to prevent accidental operation of the automation.
- 24) The end-user must not attempt to repair or adjust the automation. These operations must be carried out exclusively by qualified personnel.
- 25) **Any operations not explicitly described in these instructions are not permitted.**

AUTOMATION 844 & 844 MPS

These instructions apply to the following models:

844 MC Z16 CR - 844 MC CR - 844 MC CAT - 844 MC RF

The FAAC model 844 automation for sliding gates is an electromechanical operator which transmits movement to the gate leaf by means of a rack and pinion or drive chain coupled in appropriate manner to the sliding gate.

The irreversible system ensures that the gate is mechanically locked when the motor is not in operation and therefore it is not necessary to install a lock.

The gear motor is equipped with an adjustable mechanical clutch which affords the necessary adjustable anti-crushing safety. A release device allows the gate to be operated manually in the event of a power failure or malfunction.

According to the model, the electronic control unit is either supplied with the motoriduttore or separately and is to be housed inside the operator.

The automation 844 has been designed and built for vehicle access control. Do not use for any other purpose.

1. DESCRIPTION AND TECHNICAL CHARACTERISTICS

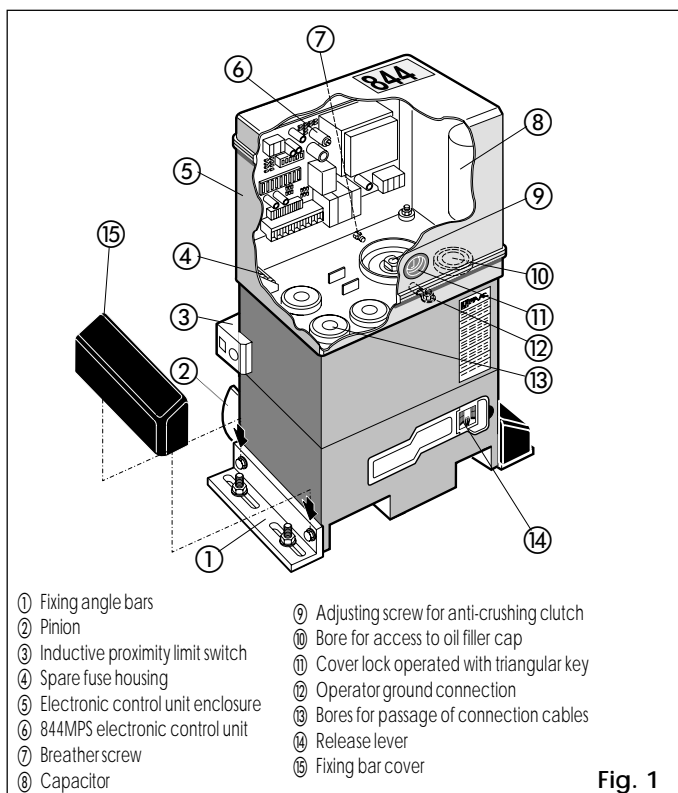

Fig. 1

1.1. MAXIMUM UTILISATION CURVE

The curve allows the maximum working time (T) to be obtained as a function of duty cycle (F).

E.g.: the 844 operators can work continuously at a duty cycle of 30%.

To ensure good operation, keep to the field of operation lying below the curve.

Important: The curve refers to a temperature of 24°C. Exposure to direct sunlight can result in a reduction in duty cycle to as low as 20%.

Calculating duty cycle

The duty cycle is the percentage of effective working time (opening + closing) with respect to the total cycle time (opening + closing + pause times).

It is calculated using the following formula:

$$\%F = \frac{Ta + Tc}{Ta + Tc + Tp + Ti} \times 100$$

where:

Ta = opening time

Tc = closing time

Tp = pause time

Ti = interval between one complete cycle and the next.

Graph of duty cycle

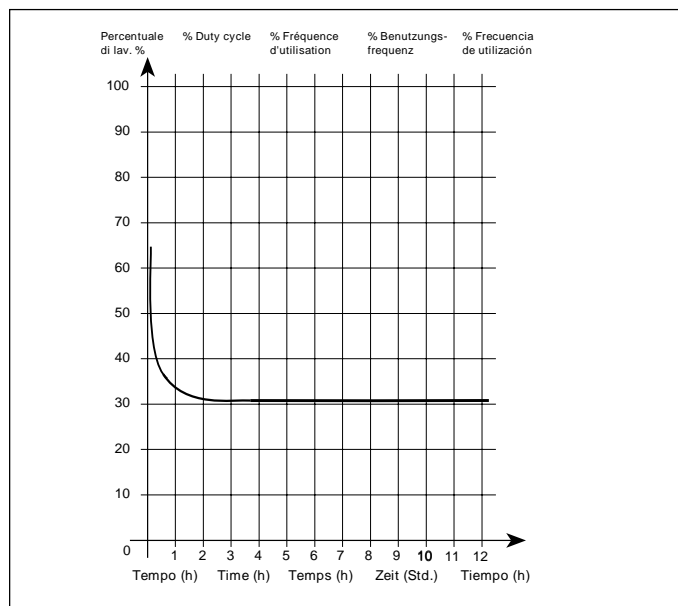

TABLE 1 TECHNICAL SPECIFICATIONS OF 844 OPERATOR

MODEL	844
Power supply	230V- (+ 6 % - 10 %) 50Hz
Power consumption (W)	650
Reduction ratio	1 ÷ 30
No. of pinion teeth	Z16 - (Z20)
Rack	4 module pitch 12,566
Max. thrust daN	110 (Z16) - 88 (Z20)
Max. torque (Nm)	35
Winding thermal protection	135 °C
Duty rating	30 % (see graph)
Oil quantity (l)	1,8
Type of oil	FAAC XD 220
Temperature range	-20 to +55 °C
Gear motor weight (kg)	15
Housing protection	IP 55
Max. gate weight (kg)	1800 (Z16) - 1000 (Z20)
Gate speed (m/min)	9,5 (Z16) - 12 (Z20)
Max. gate length	40m (Z16) - 50m (Z20)
Clutch	bidisk in oil bath
Housing treatment	cataphoresis
Control unit	844MPS
Limit switches	inductive with stop plates
Gear motor dimensions LxHxD (mm)	see Fig. 3
Electric motor technical specifications	
Motor speed (rpm)	1400
Power consumption (W)	650
Current draw (A)	3.5
Surge condenser	35µF
Power supply	230V- (+ 6 % - 10 %) 50Hz

2. DIMENSIONS

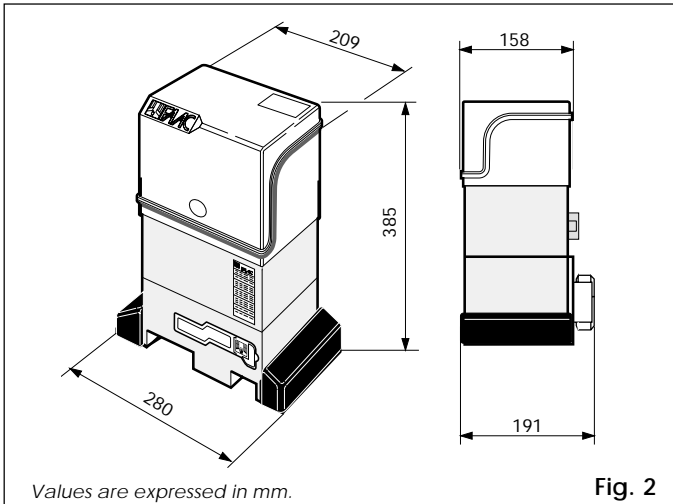

Fig. 2

3. ELECTRICAL SET-UP (standard system)

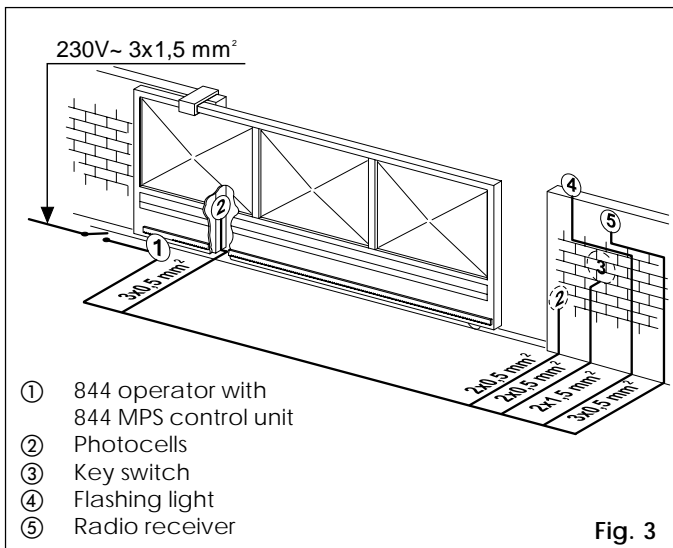

Fig. 3

4. INSTALLING THE AUTOMATION

4.1. PRELIMINARY CHECKS

For safe, correct operation of the automation, make sure that the following requirements are met:

- The gate's structure must be suitable for automation. Take special care to ensure that the wheels are large enough to support the full weight of the gate, that a top runner is installed and that physical stops are fitted to prevent the gate from coming off the runner.
- The characteristics of the ground must ensure sufficient support for the foundation plinth.
- There must be no pipes or electrical cables in the area to be dug for installing the foundation plinth.
- If the gear motor is located in a vehicle transit area, it is advisable to provide protection against accidental collisions.
- Check that the gear motor has an efficient earth connection.

4.2. INSTALLING THE BASE PLATE

- 1) Assemble the base plate as shown in Fig.4.
- 2) The base plate must be positioned as shown in Fig. 5 (right-handed closure) or Fig. 6 (left-handed closure) to ensure that the pinion and rack mesh correctly.
- 3) Prepare a foundation plinth as shown in Fig. 7 and install the base plate providing one or more conduits for electrical cables. Use a level to check that the plate is perfectly horizontal and wait for the cement to set.

- 4) Lay the electrical cables for connection to the accessories and the electricity supply as shown in Fig. 3. For ease of connection, ensure that the cables protrude by about 45 cm from the hole in the base plate (Figs. 5-6 ref. ❶).

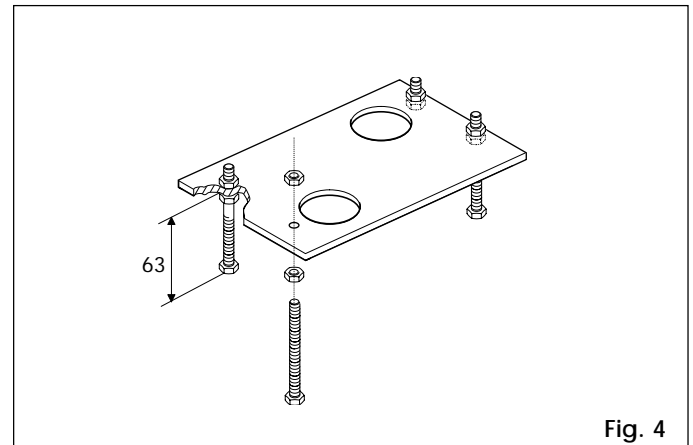

Fig. 4

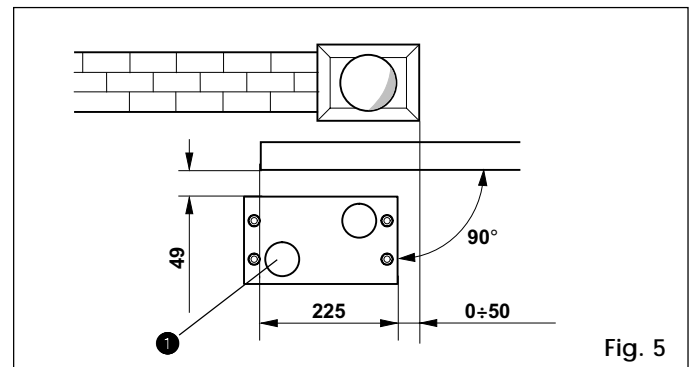

Fig. 5

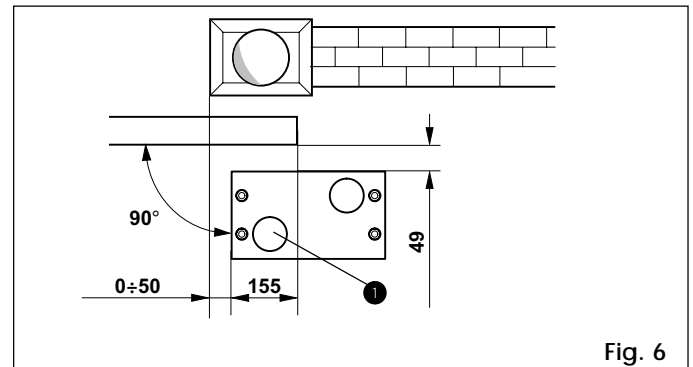

Fig. 6

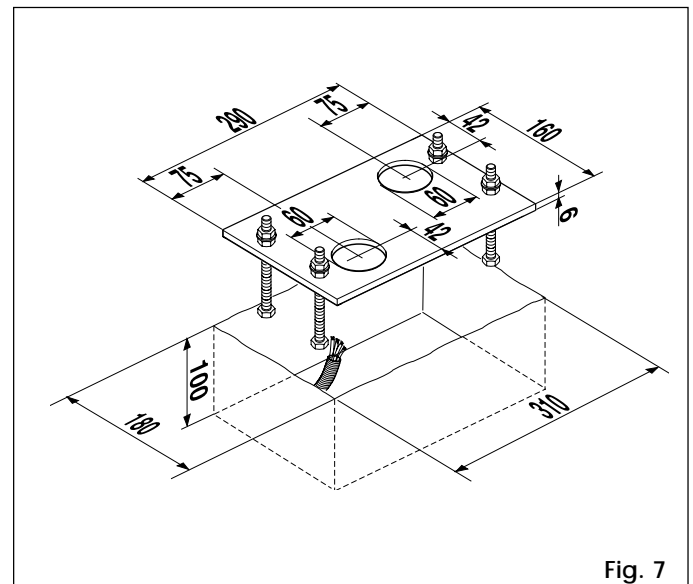

Fig. 7

4.3. MECHANICAL INSTALLATION

- 1) Fix the angle bars and the vibration dampers to the operator as shown in Fig. 8.
- 2) Open the cover of the operator using the triangular key supplied (Fig. 9).
The cover will remain in the open position thanks to a locking system.
- 3) Fix the operator to the base plate using the nuts and washers supplied (Fig. 10).
During this operation, route the cables through the conduit in the lower half of the operator.
To access the electronic equipment, route the cables through the holes provided (13, Fig. 1) using the grommets supplied.
- 4) Adjust the height of the feet and the distance from the gate as shown in Fig. 11.
- 5) Secure the gear motor onto the base plate by tightening the nuts as shown in Fig. 12.
- 6) Set the operator for manual operation as described in section 7.
- 7) Remove the breather screw as shown in Fig. 13 and keep it in a safe place.

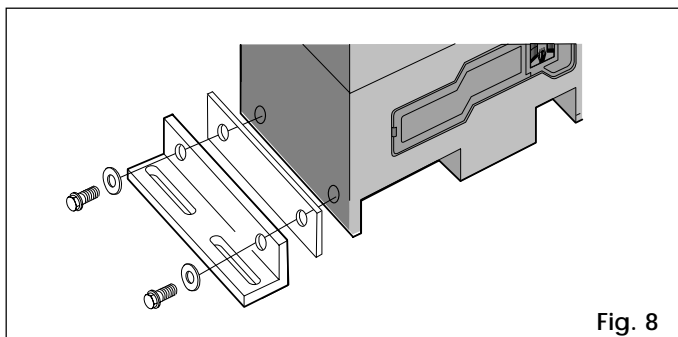

Fig. 8

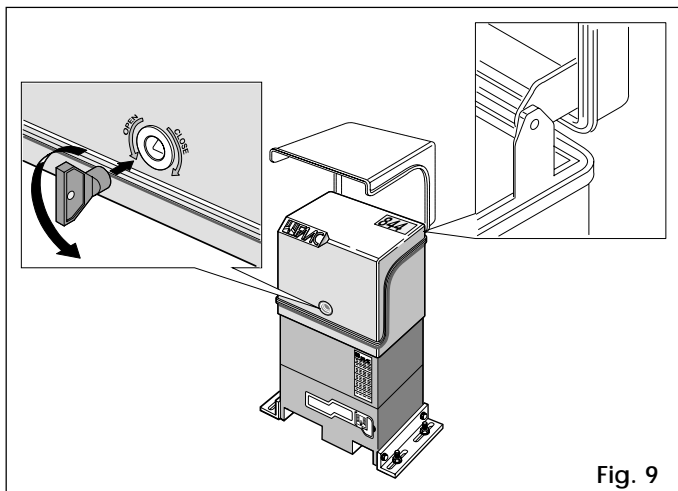

Fig. 9

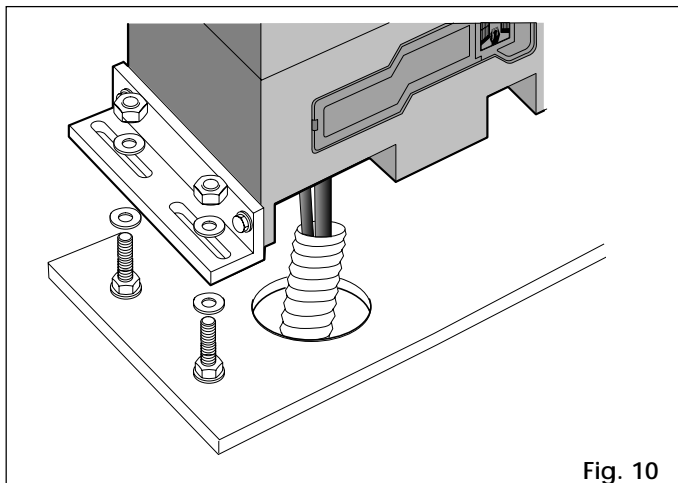

Fig. 10

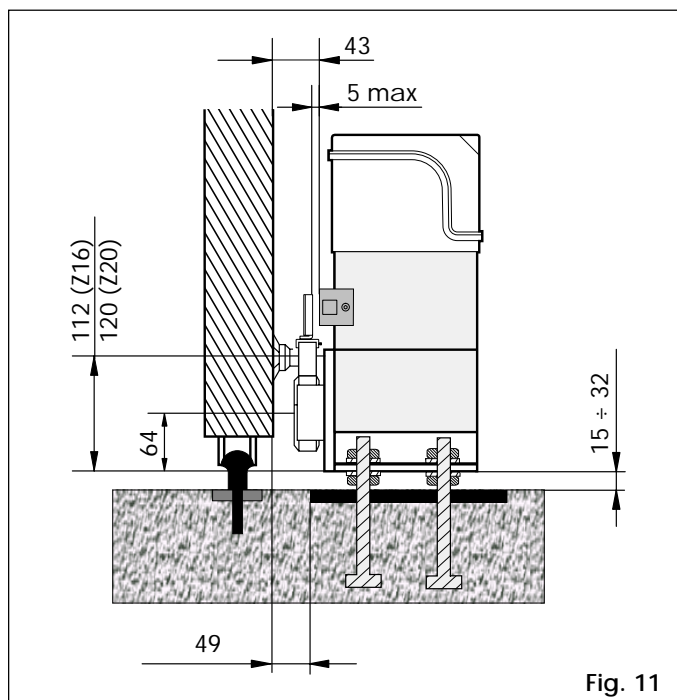

Fig. 11

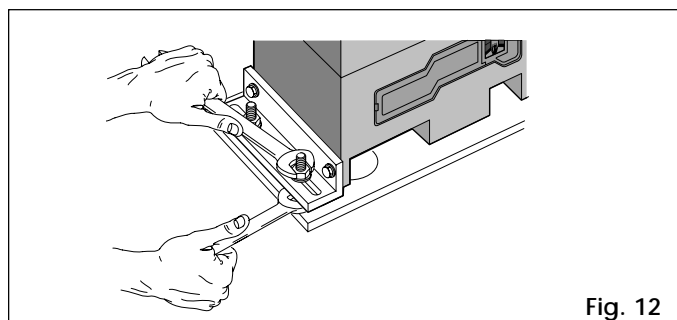

Fig. 12

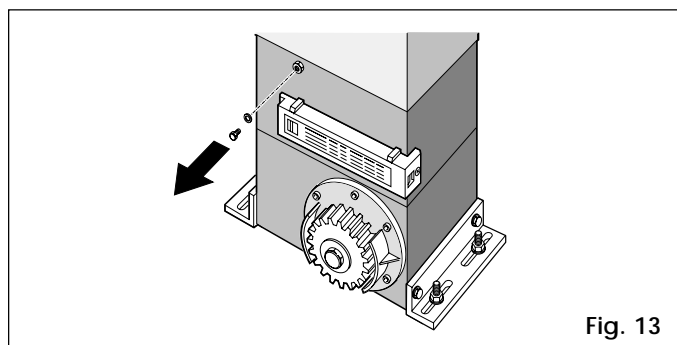

Fig. 13

4.4. FITTING THE RACK

4.4.1. WELD-ON STEEL RACK (Fig. 14)

- 1) Mount the three threaded bushes on the rack element, positioning them in the upper part of the slot. In this way the play provided by the slot will allow for future adjustment.
- 2) Slide the gate leaf manually to the closed position.
- 3) Rest the first rack element level on the pinion and weld the first threaded bush onto the gate as shown in Fig. 16.
- 4) Slide the gate manually making sure that the rack rests on the pinion. Weld the second and third bushes.
- 5) Position another rack element next to the first and use a section of rack to set the teeth of the two elements in phase as shown in Fig. 17.
- 6) Open the gate manually and weld the three threaded bushes. Proceed in this manner until the rack covers the entire length of the gate.

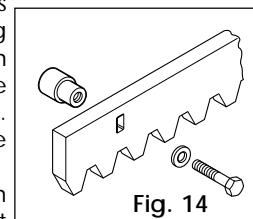

Fig. 14

4.4.2. SCREW-ON STEEL RACK (Fig. 15)

- 1) Slide the leaf manually to the closed position.
- 2) Rest the first rack element level on the pinion and insert the spacer in the upper part of the slot between the rack and the gate.
- 3) Mark the point to be drilled on the gate. Drill a 6.5 mm diameter hole and thread using 8 mm screw taps. Tighten the bolt.
- 4) Slide the gate manually making sure that the rack rests on the pinion and repeat the operations of point 3.
- 5) Place another rack element next to the first and use a section of rack to set the teeth of the two elements in phase as shown in Fig. 17.
- 6) Slide the gate manually and secure the rack element in the same manner as the first element. Proceed in this manner until the rack covers the entire length of the gate.

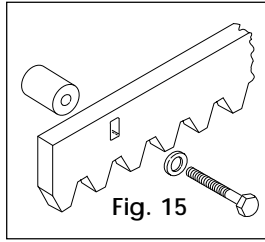

Fig. 15

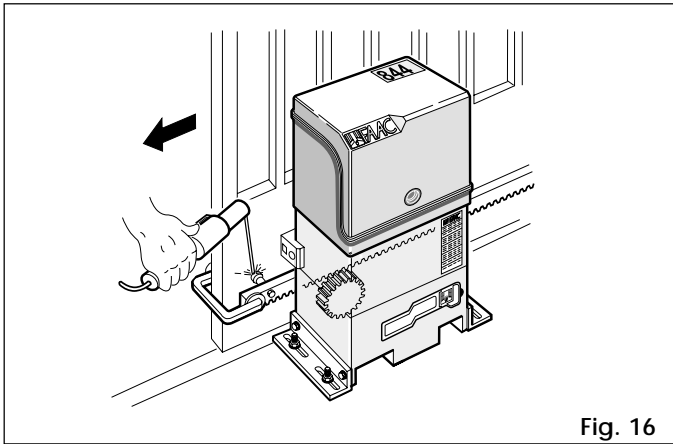

Fig. 16

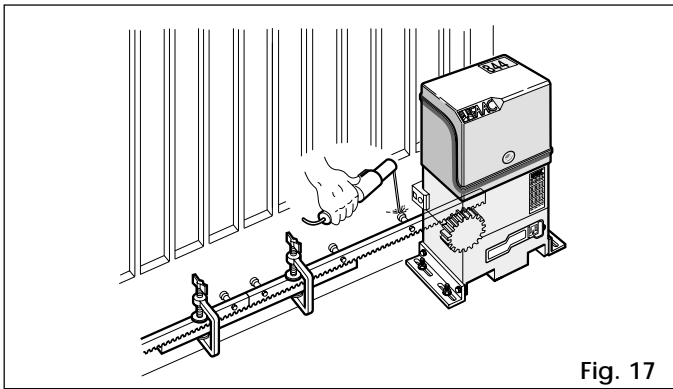

Fig. 17

Notes on the installation of the rack

- Check that none of the rack elements come off the pinion during the movement of the gate.
- Do not weld the rack elements either to the spacers or to each other.
- After installing the rack, lower the position of the gear motor by adjusting the feet (Fig. 18) by about 1.5 mm to ensure correct meshing with the pinion.
- Check manually that the gate reaches the mechanical travel limits correctly and that it does not encounter friction during its travel.
- Do not use grease or other lubricants between the pinion and the rack.

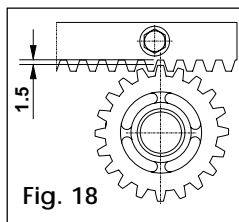

Fig. 18

4.5. MOUNTING CHAIN PINIONS

In versions with chain and sprocket drive transmissions, mount

the Z16 or Z20 chain pinion. Proceed as follows:

4.5.1. MODEL 844MC CAT (Figg. 19 - 20)

- Insert the spring pin in the shaft with the aid of a hammer.
- Fit the chain pinion on the shaft, ensuring that the notch in the pinion coincides with the spring pin, fit the screw and washers and tighten.

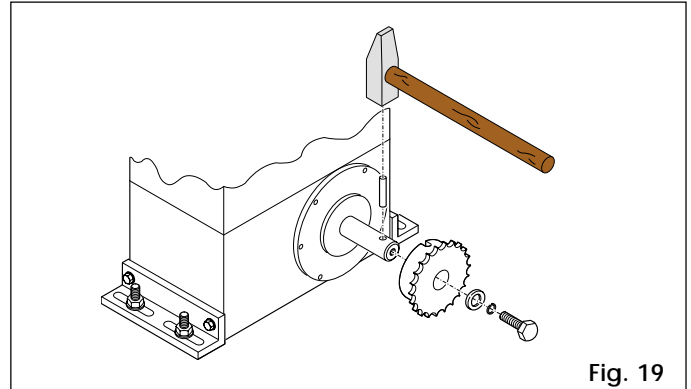

Fig. 19

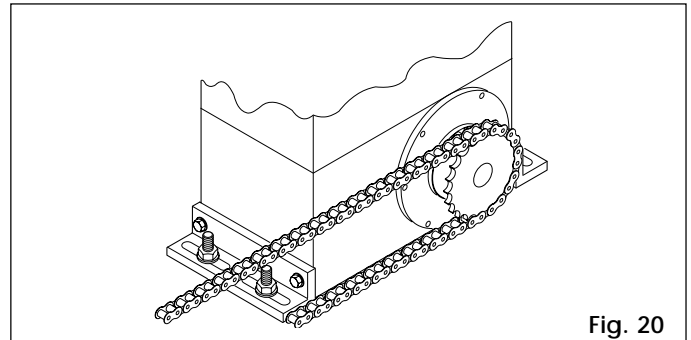

Fig. 20

4.5.2. MODEL 844MC RF (Figs. 21 - 22)

- Insert spring pin ⑦ in the shaft with the aid of a hammer.
- Fit the chain pinion on the shaft, ensuring that the notch on the pinion coincides with the spring pin; fit screw ④ and washers ⑤ and ⑥ and tighten.
- Fit the idle sprocket carrier plate on the gear motor flange, removing the four upper bolts and replacing them with the 5x12 hex bolts ① and washers ② in the kit as shown in Fig. 21.
- Fit the chain as shown in Fig. 22 and fit the casing with screws ① and washers ③ (Fig. 21).

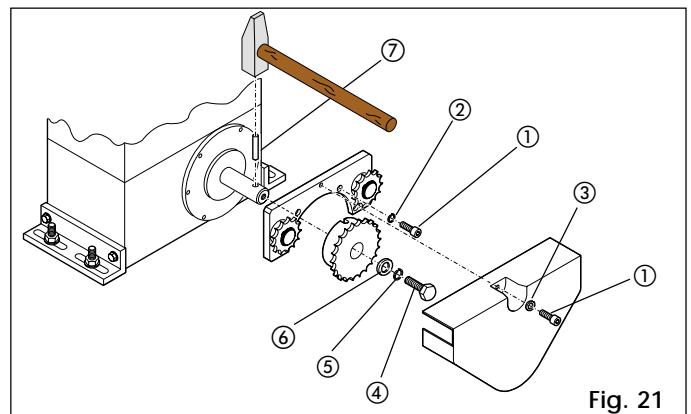

Fig. 21

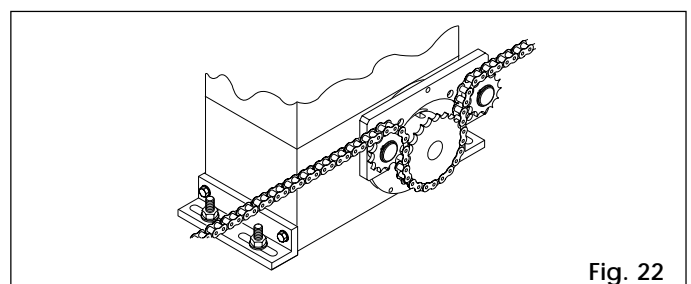

Fig. 22

5.4. FAULT CONDITIONS

The following conditions effect normal operation of the automation:

- ① microprocessor error
 - ② intervention of the electronic safety timer (interruption of operation after continuous working time exceeds 255 seconds).
 - ③ disconnection of the limit switch cable connector
- Conditions ① and ② have the sole effect of causing the automation to stop.
 - Condition ③ causes an alarm condition inhibiting all operation:

normal operation is only resumed after the cause of the alarm has been eliminated and the RESET button has been pressed (or the power supply has been momentarily interrupted).

To signal this condition, the warning light must be connected: an alarm condition is signalled by rapid flashing (0.25 sec) of the warning light.

5.5. POSITIONING THE TRAVEL STOP PLATE

The 844 operator is fitted with an inductive proximity limit switch (Fig.1 - ref.3). When the latter detects the passage of a plate fastened to the top of the rack, it stops the movement of the gate. To position the two travel stop plates correctly, proceed as follows:

- 1) Connect the limit switch connector to the 844MPS control unit in accordance with the direction of gate closure (paragraph 5.2.3. and Figs. 29/30).
- 2) Assemble the limit switch, positioning the stop plate centrally relative to the threaded studs of the bracket (Fig.34).
- 3) Switch on the power supply.
- 4) Move the gate by hand towards it closed position, stopping approximately 2 cm from the physical stop of the gate.
- 5) Set brake-adjusting trimmer TR1 approximately to its central position (Fig. 23 - ref. TR1).
- 6) Slide the travel stop plate on the rack in the opening direction. When the LED of the opening travel limit switch (FCA) in the 844 electronic control unit (Fig. 33) goes out, advance the travel stop plate by approximately 45 mm, and fix it to the rack by tightening the screws.
- 7) Move the gate by hand towards its closed position, stopping approximately 2 cm from the physical stop of the gate.
- 8) Slide the travel stop plate on the rack in the closing direction. When the LED of the closing travel end limit switch (FCC) in the 844 electronic control unit goes out, advance the travel stop plate by approximately 45 mm, and fix it to the rack by tightening the screws.
- 9) Re-lock the system (see paragraph 5).
- 10) Run a complete cycle of the gate, to check whether the limit switch trips correctly. To adjust the limit switch positions, operate brake trimmer TR1: when the trimmer is rotated clockwise, the braking space is decreased; when the trimmer is rotated counterclockwise, the braking space is increased.

Notes on positioning the travel stop plates

- The distance between the limit switch and the travel stop plate must be $\leq 5\text{mm}$ (Fig.11).
- To avoid damaging the operator and/or interruptions to service, leave a distance of at least 2 cm from the physical stops of the gate.

5.6. TORQUE ADJUSTMENT

The 844 automation system is equipped with an anti-crushing mechanical clutch which stops the opening/closing movement when the gate encounters an obstacle.

When the obstacle is removed, the gate resumes its movement until the relevant limit switch trips or the safety time (TIME OUT) is exceeded.

This torque limiter must be set in compliance with current standards.

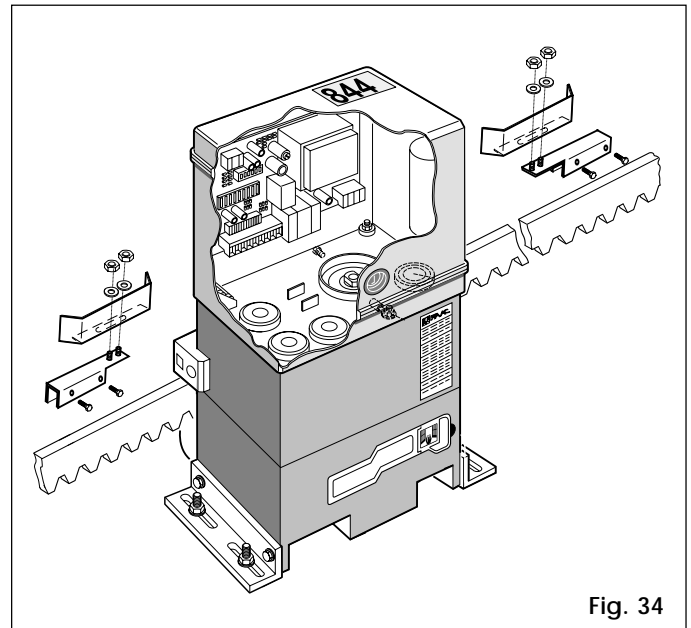

Fig. 34

To adjust the threshold of the anti-crushing system, proceed as follows:

- 1) **Switch off the power supply.**
 - 2) Remove the cover of the relevant bore (Fig. 1- ref. 9), and unscrew the cap of the clutch adjusting screw (Fig. 19).
 - 3) Keep the driving shaft in position by means of the supplied lever, and adjust the clutch as shown in Fig. 36. To increase torque, turn the screw clockwise. To decrease torque, turn the screw counterclockwise.
 - ➔ **the operator is supplied with the clutch set to maximum torque. Initially, the working torque of the system must be decreased.**
 - 4) Switch on the power supply and check whether the anti-crushing system trips correctly.
- ➔ The operator is factory-equipped with a clutch adjustment spring for gates weighing up to 1,000 kg. For heavier gates, fit the spring supplied. The procedure for replacing the spring is shown in Fig.37.

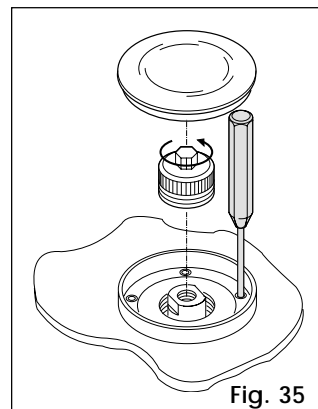

Fig. 35

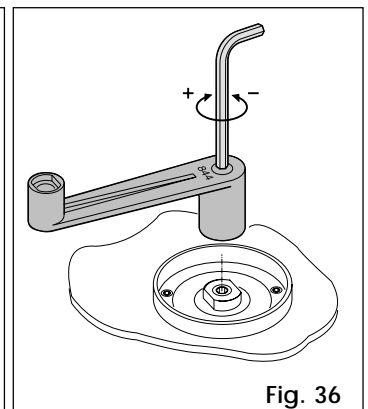

Fig. 36

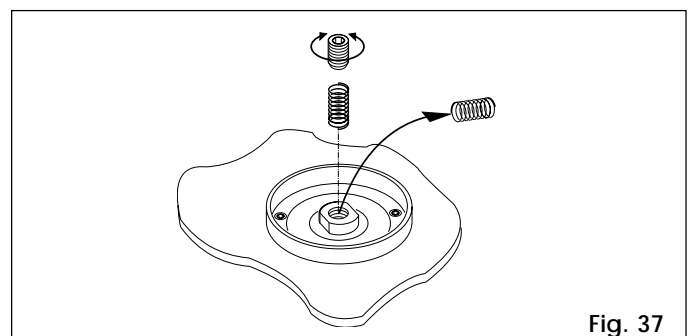

Fig. 37

6. TESTING THE AUTOMATION

When installation is complete, affix the danger warning label to the top of the casing (Fig. 38). Press fit the covers over the operator fixing bars (Fig. 39). Thoroughly check operation of the automation and all connected accessories. Give the customer the User Guide. Explain correct use and operation of the gear motor and draw attention to the potential danger zones of the automation.

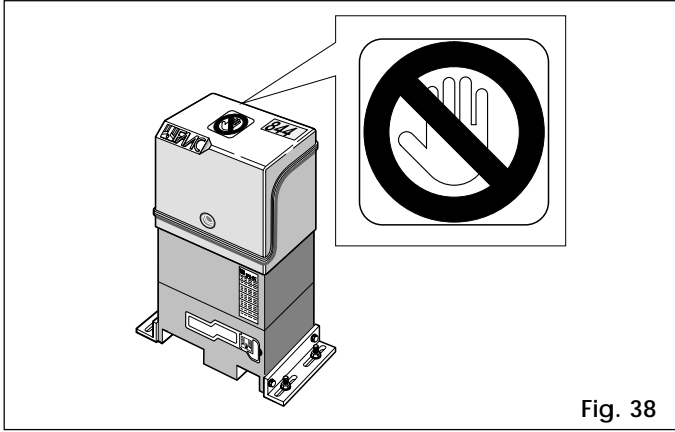

Fig. 38

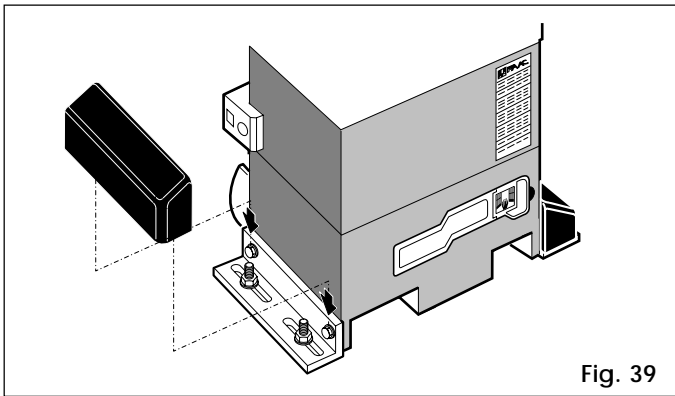

Fig. 39

7. MANUAL OPERATION

If it is necessary to operate the gate manually due to a power failure or malfunction of the automation, operate the release device as follows.

- 1) Open the lock cover and insert the key supplied in the lock (Fig.40).
- 2) Turn the key clockwise and pull out the release lever as shown in Fig.41.
- 3) Open or close the gate manually.

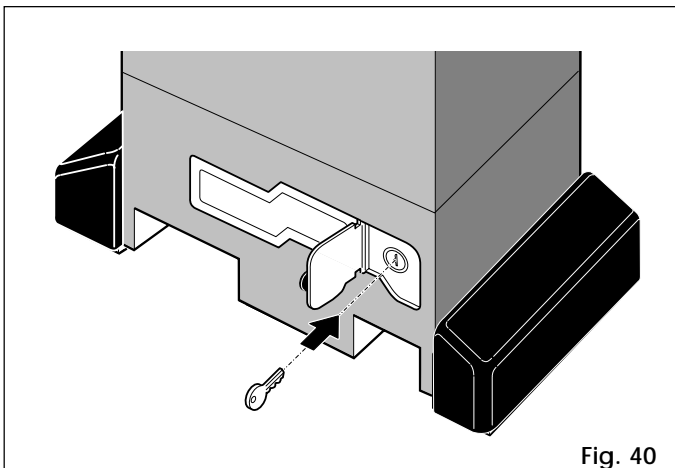

Fig. 40

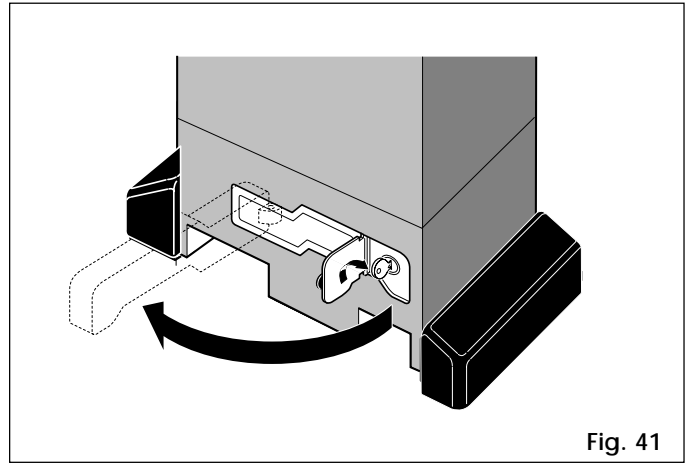

Fig. 41

8. RETURN TO NORMAL OPERATION

To prevent accidental operation of the gate during this procedure, turn off the electricity supply to the system before relocking the operator.

- 1) Close the release lever.
- 2) Turn the key anti-clockwise.
- 3) Remove the key and close the lock cover.
- 4) Move the gate until the release device engages.

9. SPECIAL APPLICATIONS

There are no special applications.

10. MAINTENANCE

When performing maintenance, always check that the anti-crushing clutch is correctly adjusted and that the safety devices operate correctly.

10.1. TOPPING UP WITH OIL

Check the quantity of oil in the operator periodically. For medium-low duty cycles an annual check is sufficient; for more intensive use, check every 6 months. To access the oil reservoir, remove the the oil filler cap (Fig.1 rif.10).

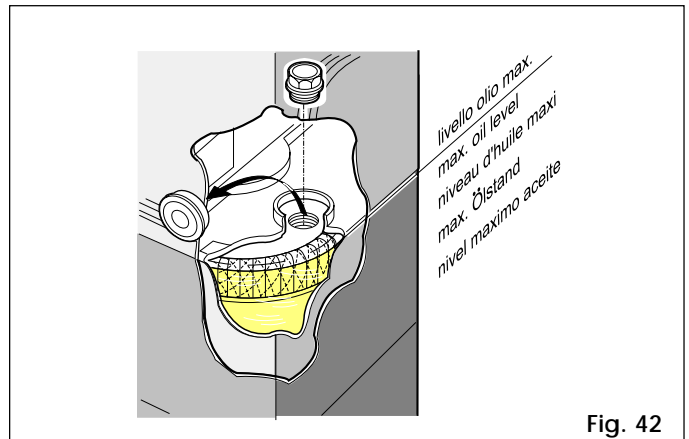

Fig. 42

The oil level should be up to the copper windings of the electric motor (Fig. 42).

To top up, pour in oil to the correct level. Use exclusively FAAC XD 220 oil.

11. REPAIRS

For repairs contact an authorised FAAC Repair Centre.

USER'S GUIDE

844 AUTOMATION

Read the instructions carefully before using the product and keep them for future reference.

GENERAL SAFETY INSTRUCTIONS

The 844 automation, when installed and used correctly, affords a high level of safety.

However, some simple rules should be followed to avoid accidents:

- Do not stand in the vicinity of the automation or allow anyone else, especially children, to do so, and do not place objects in the vicinity of the automation. This is particularly important during operation.
- Keep remote controls or any other control devices out of the reach of children to prevent them from accidentally operating the automation.
- Do not allow children to play with the automation.
- Do not deliberately obstruct the movement of the gate.
- Make sure that branches or bushes do not interfere with the movement of the gate.
- Ensure that the signalling lights are efficient and clearly visible.
- Do not attempt to move the gate manually without first releasing it.
- In the event of a malfunction, release the gate to allow access and call a qualified technician for service.
- After setting manual operation, disconnect the electricity supply from the system before returning to normal operation.
- Do not make any modifications to components of the automation system.
- Do not attempt to perform any repair work or tamper with the automation. Call FAAC qualified personnel for repairs.
- At least once every six months have the automation, the safety devices and the earth connection checked by a qualified technician.

DESCRIPTION

The FAAC 844 automation is ideal for controlling vehicle access areas with medium-high transit frequencies.

The FAAC model 844 automation for sliding gates are electromechanical operators which transmit movement to the leaf by means of a pinion with rack or chain coupled in appropriate manner to the sliding gate.

The operation of the sliding gate is controlled by an electronic control unit housed inside the operator.

When the gate is closed, on receipt of an opening impulse from a remote control or other suitable control device, the control unit will start the motor to move the gate to the open position. If automatic operation has been selected, sending an impulse causes the gate to reclose on its own after the selected pause time.

If semiautomatic operation has been selected, a second impulse must be sent to reclose the gate.

An opening impulse sent while the gate is reclosing causes it to change direction of movement.

A stop command (if available) stops movement at any time.

For detailed information on operation of the sliding gate in the various operating modes, contact the installation technician. The automations have safety devices (photocells) which prevent the gate from reclosing when an obstacle lies within the area they are protecting.

The system ensures mechanical locking when the motor is not in operation, so it is not necessary to install a lock.

For this reason the release system must be operated before the gate can be opened manually.

The gear motor has mechanical clutch which affords the necessary anti-crushing safety.

An inductive sensor detects the passage of the metal stop plates fixed to the rack in correspondence with the travel limit

positions. The electronic control unit is incorporated in the gear motor.

A convenient manual release device allows the gate to be operated in the event of a power failure or malfunction. The light flashes while the gate is moving.

MANUAL OPERATION

If the gate has to be operated manually due to a power failure or malfunction of the automation, use the release device as follows.

- 1) Open the lock cover plate and insert the key supplied in the lock (Fig.1).
- 2) Turn the key clockwise and pull the release lever as shown in Fig. 2.
- 3) Open or close the gate manually.

RETURN TO NORMAL OPERATION

To prevent accidental operation of the gate during this procedure, turn off the electricity supply to the system before relocking the operator.

- 1) Reclose the release lever.
- 2) Turn the key anti-clockwise.
- 3) Remove the key and close lock cover plate.
- 4) Move the gate until the release device engages.

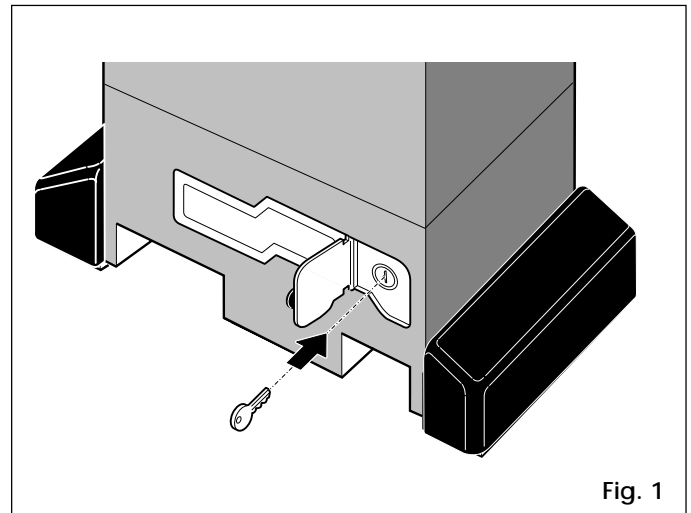

Fig. 1

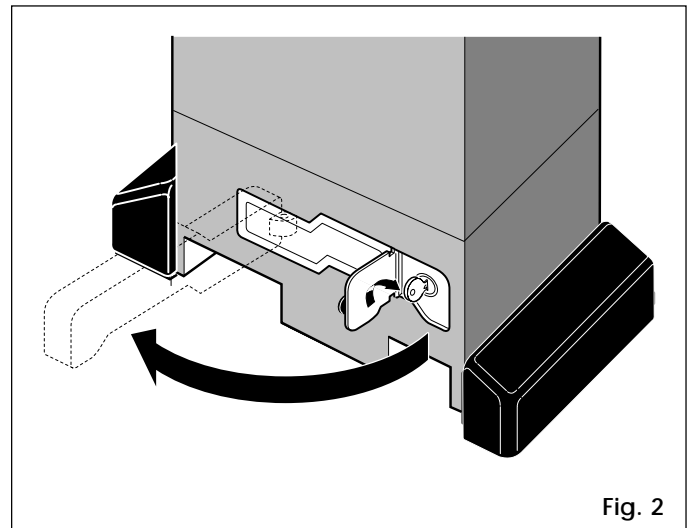

Fig. 2

6961K Control

For Sliding Gates

Model 844

LIFTMASTER ELECTRONICS PTY LTD

Phone: (02) 9699 9654 Fax: (02) 9699 8443

696 - 1101 REV.02

6961K MODE SELECTIONS

PLEASE CONSULT LIFTMASTER IF OTHER MODE FUNCTIONS ARE REQUIRED

MODE 1 DOMESTIC

Gate opens on impulse and closes off a second impulse. While opening a pulse will stop the gate from fully opening. The next pulse will close the gate. When used, if the Photo Electric (PE) is interrupted while closing or a pulse is applied, the gate will re-open and a second pulse is required for the gate to re-close.

MODE 2 PHOTO ELECTRIC CLOSE

Gate opens on impulse and closes only after the PE is broken and cleared. While closing, if the PE is interrupted, the gate will re-open fully and close after preset time (VR3).

MODE 3 AUTO CLOSE with SAFETY REVERSE

Gate opens on impulse and closes automatically after a preset time (Refer VR3). While closing, if the PE is interrupted or a pulse is applied, the gate will re-open fully and re-close after the preset time expires (VR3) and PE's are cleared.

MODE 4 SECURITY MODE

Gate opens on impulse and closes after preset time (VR3). If the PE is interrupted during the opening cycle, the gate will continue to open until the PE is cleared. The gate will then close after PE is cleared and VR3 time expires.

MODE 5 HIGH SECURITY MODE

Gate opens on impulse and closes automatically after preset time (VR3). While opening, if PE is interrupted, gate will stop, and then re-close after preset time and PE is cleared. While closing, if PE is interrupted, gate will stop and continue closing when PE is cleared and VR3 time expires.

MODE 6 AUTO CLOSE with TIMER RESTART MSS SWITCHES 2, 4 & 8 ON

Gate opens on impulse and closes automatically. While opening, a second pulse will restart the open timer. PE can be added for safety only.

ACCESSORIES

PUSH BUTTON/KEYSWITCH

Connect voltage free N.O. contacts to terminals 17 & 18

PEDESTRIAN MODE

By applying a pulse between terminal 17 (com) and 19 (ped) the gate, or pair of gates, will partly open for 5 seconds. Gate(s) will close subject to mode selection.

CLOCK TIMER MODE

By bridging terminals 17 & 20 with N.O. voltage free contacts, the gate will open and remain open until bridge is removed and PE is cleared.

LIGHT INDICATOR

An output is available via JP3 to switch a 12V DC relay. The relay will be activated when the gate is opening or closing only.

INSTALLATION NOTES:

- VR1 controls the opening travel time and VR2 controls the closing travel time. VR3 controls the hold open time after the safety device has been activated.
- Set open timer pots (VR1 & VR2) 2-5 seconds longer than the actual travel time (turn clockwise to increase travel time), otherwise gate may stop before completing its open or close cycle.
- Green LED 4 will stay on while gate is in the open position and must turn off when gate is closed and timer is off. If Green LED 4 turns off when gate is open, invert limit wires 9 & 10, the wires 4 & 5 on the motor terminals, and blue and white wires on JP3 plug.
There are two limit light indicators (Green LED 1 and Red LED 2). The Green LED will turn off when the gate is fully open, and the Red LED when the gate is fully closed
- Red LED 3 will be on when PE is interrupted or not properly aligned.
- Safety loop, if used, connect the N.C. contact from the output relay to terminals 15 & 16. For exit loop connect N.O. contacts to Terminals 17 & 18.
- Board must be connected to main Earth via JP1, pin 2.

Electronic Brake

Incorporated in the limit converter board is an electronic brake to stop the motor the instant the proximity switch is activated. Note: Increasing the adjustment too much will cause the motor to over reverse.

For Adjustment:

OPEN - controls the open brake time

CLOSE - controls the close brake time

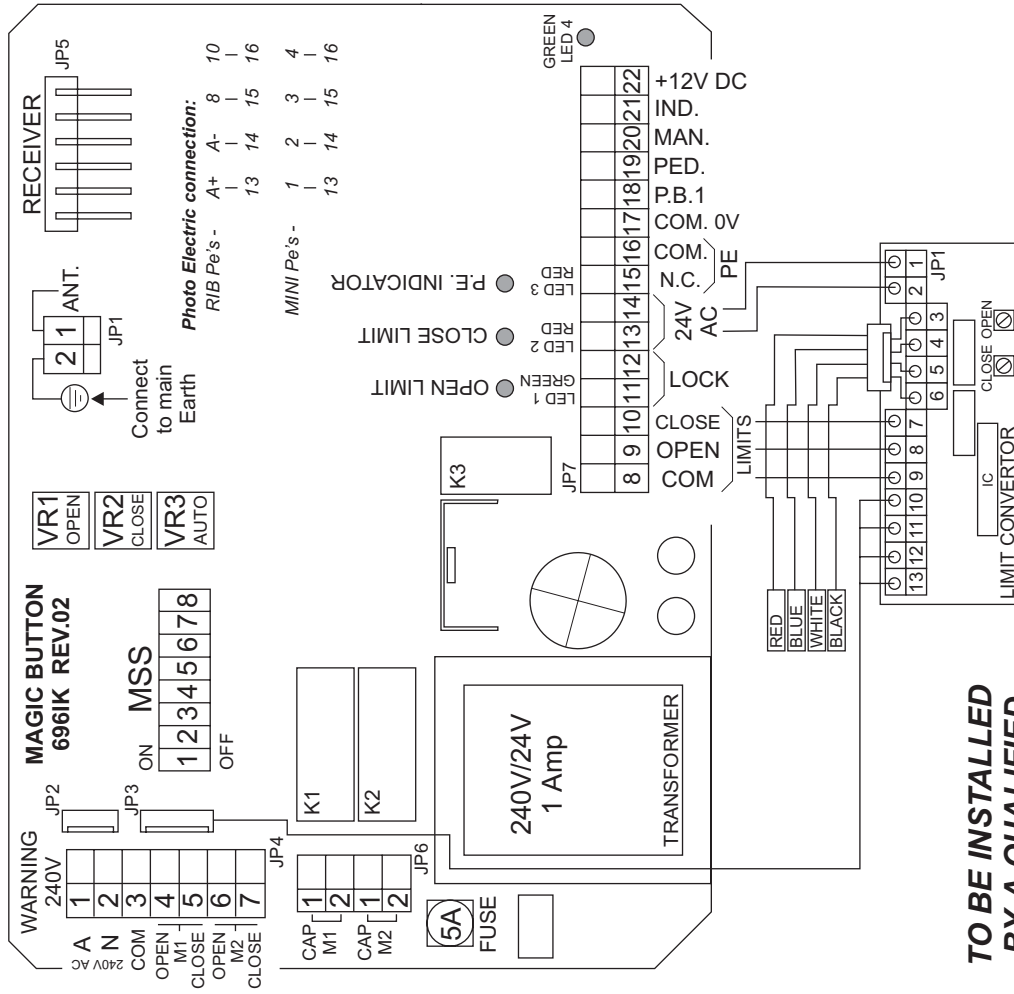

TO BE INSTALLED BY A QUALIFIED ELECTRICIAN