

Underground gate operator **SUB300**

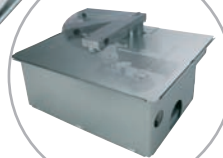

Release

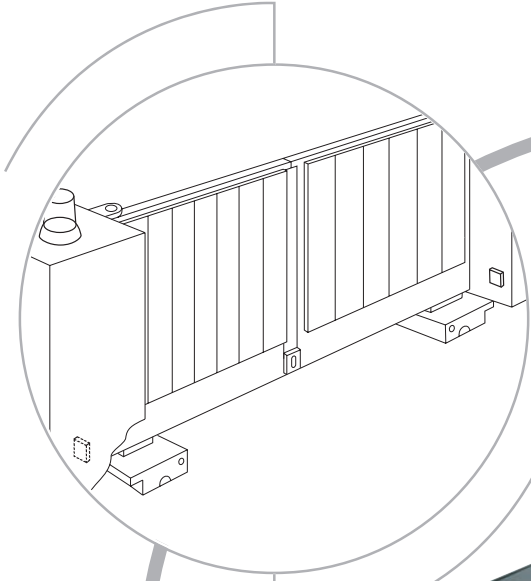

Manual Release



Motor

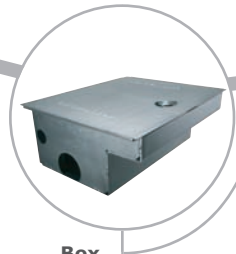

Box



110° Arm

Install all equipment in compliance with EN60335-2-103



2-year warranty

SUB300

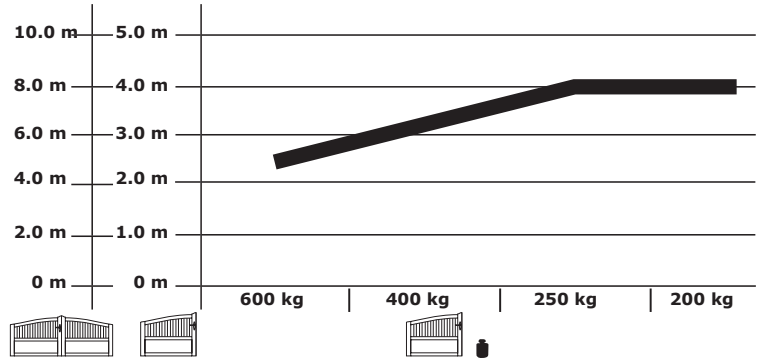
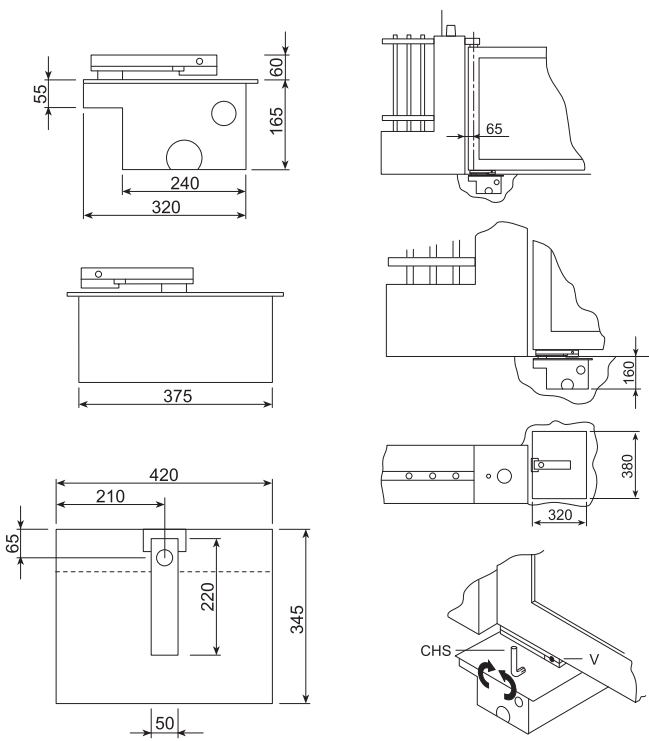

SUB100S – Retrofit adapter arm



SUB-180 – 180° Arm



SUB-110 – 110° Arm

Technical Data

		SUB300	SUB300-24
Voltage IN	VAC	220-240	220-240
Frequency	Hz	50	50
Motor voltage	V	230VAC	24VDC
Power (nom)	W	300	80
Current	A	2,1	3,52
Torque (max)	Nm	380	380
Capacitor	yF	10	not required
Thermal overload protection	°C	150°	not required
Motor speed	rpm	1400	1400
Duty cycle	cycles/hr	~20	~40
Working temperature range	°C	-25°C/+55°C	-25°C/+55°C
Protection class		I	I
Degree of protection	IP	IP67	IP67
Motor weight (~)	kg	10	10
Max. gate wing length	m	4,0	4,0
Max gate weight at max. wing length incl. 20% reserve	kg	600kg at 2.5m	600kg at 2.5m

For more accessories please refer to accessory catalog

Model & carton content chart

Model	Drive unit	Capacitor	Electronic control	Remote control 94335E	Receiver & radio	Foundation box	Drive arm	IR sensor	Flashing light	Key switch	Antenna kit	Number of cartons
SUB300	1x	•										1
SUB300-24	1x											1
SUB300K	2x	•	•	2x	433MHz	•*	•**	•	•	•	•	9

* SUB300B Zinc coated box included

** SUB-110 110° opening arm included